



# AquaTech Pressmain

## INSTRUCTIONS FOR

0. GENERAL SAFETY INFORMATION, WARNINGS & CAUTIONS
1. INSTALLATION
2. THE USER
3. SERVICING
4. DISPOSAL

## VARIMATIC LG2 SERIES COLD WATER PRESSURE BOOSTER SETS WITH VARIABLE SPEED & SMART RELAY CONTROL

MODEL: LG2AV



**WRAS**  
APPROVED  
PRODUCT

**CE**

ISSUE: 4 1/02/08

---







Head Office: AGM House, London Rd, Copford, Colchester, Essex CO6 1GT UK  
Tel: 01206 215121 Fax: 01206 215131

Manchester Office: Dolphin House, 130 Princess Road, Manchester M16 7BY  
Tel: 0161 226 4727 Fax: 0161 226 5848

**AGM**  
group member



# CONTENTS

	<b>0.0 GENERAL SAFETY INFORMATION</b>		<b>4</b>
0.1	 WARNINGS		4
0.2	 CAUTIONS FOR INSTALLATION		5
0.3	 CAUTIONS FOR OPERATION/USER		7
0.4	 CAUTIONS FOR MAINTENANCE		7
<b>1.</b>	<b>INSTALLATION INSTRUCTIONS</b>		<b>8</b>
1.1	ADDITIONAL WARNING		8
1.2	ADDITIONAL CAUTIONS		8
1.3	PROCEDURE		8
1.3.1	OFF-LOADING AT SITE		8
1.3.2	LOCATION		8
1.3.3	FIXING		9
1.3.4	PIPEWORK		9
1.3.5	EXPANSION, CONTROL and HYDRAULIC ACCUMULATOR VESSELS		10
1.3.6	ELECTRICAL		11
<b>2.</b>	<b>USER INSTRUCTIONS</b>		<b>12</b>
2.1	CUSTOMER ASSURANCE		12
2.2	COMMISSIONING		13
2.3	OPERATING INSTRUCTIONS		13
2.3.1	ADDITIONAL CAUTIONS		13
2.3.2	NORMAL OPERATION		14
	TO VIEW THE PARAMETERS		15
2.3.3	SYSTEM ALARMS		15
2.3.4	PUMP FAULTS		16
	LG2AV: FAULT RESETTING		16
	VENTING PUMPS		17
	REMOTE SIGNAL		18
	REMOTE ALARM PANEL IF REQUESTED		18
2.4	MAINTENANCE INSTRUCTIONS FOR VARIMATIC LG2AV		19
2.4.1	ADDITIONAL CAUTIONS		19
2.4.2	PROCEDURE		19
<b>3.</b>	<b>SERVICING</b>		<b>20</b>

3.1	MAINTENANCE AND CARE OF YOUR EQUIPMENT .....	20
3.2	LEGAL REQUIREMENTS .....	20
3.3	SERVICE CONTACTS .....	20
<b>4.</b>	<b>DISPOSAL.....</b>	<b>21</b>
	<b>EC DECLARATION OF CONFORMITY .....</b>	<b>21</b>
	<b>OPERATING PARAMETERS.....</b>	<b>22</b>

## 0.0 GENERAL SAFETY INFORMATION

- These instructions are intended for the installer/operator/user/maintenance of this equipment and must be kept with the equipment, for the life of the equipment and made available to all persons. Please read GENERAL SAFETY INFORMATION 0.0, WARNINGS 0.1 and CAUTIONS 0.2, 0.3 & 0.4 before doing anything else, and then follow them carefully.
- The unit must only be installed/operated/used/maintained by a competent person; *A competent person is someone who is technically competent and familiar with safety practices and the hazards involved.*
- Hydraulic Accumulators/Expansion Vessels installed as part of/in conjunction with this equipment, with Pressure x Volume above 250 Bar-litres, require regular formal inspection by a *competent person*. This is a Legal Requirement under the "Pressure Systems Safety Regulations" (PSSR) and the Owner/User should be made aware of their responsibility for this. (see section 3. Servicing).
- Failure to install/operate/use/maintain the equipment as recommended below could cause damage to the equipment any anything subsequently connected to it, and invalidate the warranty provided by AquaTech-Pressmain to the buyer.
- Any damage caused to the equipment by misapplication, mishandling or misuse could lead to risk of **Electrocution, Burns, Fire, Flooding or injury to people or property** dependent upon the circumstances involved.
- This equipment contains moving/rotating parts that must remain guarded. Removal of or missing guards could lead to serious personal injury.
- This equipment automatically restarts after a power interruption.
- We accept no responsibility or liability for any consequences or damage/losses due to misapplication, mishandling or misuse of the equipment.
- It should be noted that the assembly of pressure equipment on site under the responsibility of the user (or his representative) is not subject to the Pressure Equipment Directive 97/23/EC. (National legislation covering assembly on site will apply)
- The latest version of this instruction manual with up to date safety information can be downloaded from our website at [www.aquatechpressmain.co.uk](http://www.aquatechpressmain.co.uk)

### 0.1 WARNINGS

- 0.1.1 **Do not touch any live parts for at least 5 minutes after switching off the electricity supply. Failure to observe this will constitute a severe Electric shock and/or Burns hazard and may be lethal.**
- 0.1.2 **The equipment is only suitable for earth referenced supplies and must be permanently earthed to avoid Electric shock hazard.**
- 0.1.3 **With equipment isolator OFF, mains voltage may still be present from BMS system. This constitutes an Electric shock hazard.**
- 0.1.4 **Emergency stop button does not remove dangerous voltages from control panel/pump motor assemblies. This constitutes an Electric shock hazard.**
- 0.1.5 **Metal parts (e.g. heat sinks) may reach temperatures of 90 degrees centigrade and will constitute a Burns hazard.**
- 0.1.6 **Some equipment is designed to operate with liquid temperatures up to 150 degrees centigrade and will constitute a Burns/scalding hazard.**
- 0.1.7 **The equipment must not be pressurised beyond the maximum working pressure as stated on pumps/pipework/vessels/control panel otherwise serious mechanical damage/destruction could occur causing injury to people or property.**

- 0.1.8 The equipment must not be heated/chilled beyond the maximum/minimum working temperature as stated on pumps/pipework/vessels/control panel otherwise serious mechanical damage/destruction could occur causing injury to people or property.
- 0.1.9 Any damage to equipment, pumpset, vessels, pipework or system components caused by misapplication, mishandling or misuse could lead to Electric shock hazard, Burns hazard, Fire hazard, Flooding hazard or cause injury to people or property.
- 0.1.10 This equipment may contain moving/rotating parts that must remain guarded. Removal of or missing guards could lead to serious personal injury.
- 0.1.11 Pressure vessels must never be disassembled whilst in use, they contain high pressure air/gas charge which could cause injury to people or property.
- 0.1.12 Pump motors with lifting eyes; the lifting eyes are only suitable for lifting motors NOT the entire pump assembly. This could cause injury to people or property.
- 0.1.13 Ensure the base/foundation/plinth/wall to which the equipment is to be attached is sufficiently strong enough to carry the entire mass of the equipment including the water that it will contain under worst-case fault conditions. E.g. fully saturated pressure vessel with no air charge, break tank full to overflowing, etc. Failure to observe this could cause serious mechanical damage/destruction resulting in injury to people or property.



## 0.2 CAUTIONS FOR INSTALLATION

- 0.2.1 READ GENERAL SAFETY INFORMATION 0.0, WARNINGS 0.1 and CAUTIONS 0.2, 0.3 & 0.4
- 0.2.2 The unit should only be installed/operated by a competent person; *A competent person is someone who is technically competent and familiar with safety practices and the hazards involved.*
- 0.2.3 Do not lift the pumpset by pipework. Lift the pumpset by the container pallet using a pallet/forklift or crane by passing strops underneath the skid using a spreader bar. Failure to utilise these facilities will result in damage to the pumpset.
- 0.2.4 Store in a dry place to avoid damp conditions deteriorating the equipment.
- 0.2.5 Protect against dirt, damage and frost. It is absolutely essential that no foreign matter such as pipe thread swarf, welding slag, grit or stones are allowed to enter the set. Debris of this type can cause severe damage to the mechanical seals, diaphragms and impeller. Frost/freezing will damage pumps/pipework and control panel components.
- 0.2.6 The equipment is only suitable for installation in a clean, dust free indoor environment, with adequate protection from heat and frost, and sufficient ventilation to ensure cooling of the motors. Ambient air temperature should be between 5 and 30 degrees centigrade, non-condensating. Operation outside of these conditions could seriously damage the equipment.
- 0.2.7 If the equipment were to be stored or taken out of service for a period of time (e.g. 1 week or more), then we would recommend draining the equipment of all water/liquid (with due regard to any local regulations) to prevent frost damage to components. When restarting is required we would recommend commissioning by our authorised service agent.
- 0.2.8 Ensure the base/foundation/plinth/wall to which the equipment is to be attached has sufficient mass compared to the equipment, in order to avoid noise/vibration transmission. E.g. the mass of the base should be at least five times the mass of the equipment.
- 0.2.9 Ensure the electrical supply is the correct voltage, current, frequency and type for the equipment supplied and that suitable circuit protection equipment is installed in the supply. Incorrect electrical installation could be an electric shock/burns/fire hazard.
- 0.2.10 When accessing the control panel to make electrical connections adopt anti-static procedures e.g. wear anti-static earthed wristband, to avoid risk of damaging the controller.
- 0.2.11 All products that are packaged to include Pressure vessel(s)/Hydraulic Accumulator(s)/Expansion Vessel(s) are classed as "Assemblies" under the Pressure Equipment Directive (PED). Where units are despatched with "Loose" vessel(s) for assembly on site it is absolutely essential that they be installed as detailed in the instructions using the

fittings provided where appropriate. Failure to observe this will nullify compliance with the PED and may present a safety hazard. Your warranty may also be affected.

- 0.2.12** Where Hydraulic Accumulator(s)/Expansion Vessel(s) are supplied as a loose item, they must be installed/connected correctly before operating the equipment, otherwise serious damage from over-pressure/over temperature could occur.
- 0.2.13** Do not operate this equipment/pumpset prior to commissioning (section 2.2) This could cause irreparable damage to equipment/pumpset/pipework/system components.
- 0.2.14** Isolate the equipment/pumpset before pressure testing system. Excess pressure could irreparably damage the pressure transducer, pressure switches (where fitted) and the diaphragms of pressure vessel/hydraulic accumulators.
- 0.2.15** It is the installers' responsibility to ensure subsequent pipework etc can accept the pressures generated by the equipment/pumpset and to install an overpressure safety device into the system with due respect to the suction pressure present on the pumpset, the pump closed valve pressure stated on the pump, the maximum working pressure stated on any of the attached pressure vessels and any other device connected to the system e.g. boilers, calorifiers etc.
- 0.2.16** When chlorination of the system is carried out, ensure that any residual chlorine is removed by thorough flushing as detailed in the HSE approved code of practice L8, to avoid damaging the equipment/pumpset. The normal level of chlorination is up to 2 parts per million (ppm), but shock dosing for sterilization purposes, at 25-50 ppm for 24-48 hours is acceptable as long as all chlorine is removed once the process is complete. Chlorination beyond these limits could seriously damage pumpset components and WILL NOT be covered by the warranty.
- 0.2.17** The installer/user is responsible for the installation of the correct earthing and protection according to valid national and local standards. All operations must be carried out by a suitably qualified person.
- 0.2.18** The equipment is only suitable for earth referenced supplies and must be permanently earthed to avoid electric shock hazard.
- 0.2.19** The equipment must be permanently earthed with appropriate sized Earthing.
- 0.2.20** Equipment containing variable speed drives/motors has high earth leakage current >3.5mA and will require additional earth bonding whereby a single conductor of increased size or duplicate earth conductors must be provided.
- 0.2.21** Never perform high voltage resistance tests on control panels, variable speed drives/motors without first disconnecting the panel/drive/motor from the circuit being tested as this will damage the built in electronic components.
- 0.2.22** Equipment containing variable speed drives/motors that has been stored/not powered up for long periods of time (i.e. 1 year or more) may require the variable speed drive/motor capacitors to be reformed. Please contact AquaTech-Pressmain for more information. Failure to reform capacitors will result in drive/motor damage.
- 0.2.23** Metal parts (e.g. heat sinks) may reach temperatures of 90 degrees centigrade.
- 0.2.24** RCD's/ELCB's are not recommended for use with variable speed drives/motors. Where their use is mandatory use type B RCD's. For single phase sets with inverter motors the earth leakage circuit breaker must trip out when earth fault currents with DC content (pulsating DC) occur. For three phase sets with inverter motors the earth leakage circuit breaker must trip out when earth fault currents with DC content (pulsating DC) and smooth DC earth fault currents occur.
- 0.2.25** RCD's/ELCB's suitable for use with variable speed drives/motors are not suitable for personnel protection.
- 0.2.26** EMC - With respect to BS EN61000-3-2 this equipment is defined as 'professional equipment' and therefore the installer/user may need to seek permission from the supply utility to connect this equipment to the public low voltage mains supply.
- 0.2.27** Where "Expansion vessels" are used on Domestic hot water systems (DHWS) or LTHW heating system pressurisation units, the temperature of the fluid returning to the vessels should not exceed 70 degrees Centigrade as this could damage the vessel diaphragm. Where the temperature exceeds 70C an intermediate cooling vessel should be fitted.
- 0.2.28** Drain cocks/valves and air bleed screws must not be left open as this could cause flooding.



### 0.3 CAUTIONS FOR OPERATION/USER

- 0.3.1 READ GENERAL SAFETY INFORMATION 0.0, WARNINGS 0.1 and CAUTIONS 0.2, 0.3 & 0.4
- 0.3.2 The unit should only be operated/used by a competent person; *A competent person is someone who is technically competent and familiar with safety practices and the hazards involved.*
- 0.3.3 The Owner/User of this equipment has a Legal Responsibility to ensure that it is subject to regular formal inspections. See Section 3. Servicing, for details.
- 0.3.4 Where Hydraulic Accumulator(s)/Expansion Vessel(s) are supplied as a loose item, they must be installed/connected correctly before operating the equipment, otherwise serious damage from over-pressure could occur.
- 0.3.5 The set must not be run until commissioned by an authorised AquaTech-Pressmain agent, this could irreparably damage the pump set and/or system components/pipework connected to it.
- 0.3.6 The pumpset should be left switched ON with the pumps switched to AUTO for normal operation.
- 0.3.7 The pumpset should not be left in "Hand" operation for more than 1 minute. This could lead to severe damage of pumpset components and/or pipework system from over-pressure and/or overheating.
- 0.3.8 Ensure pumpset has an adequate water supply at all times to prevent dry running causing pump seal damage and water leakage.
- 0.3.9 Do no attempt to start pumps without liquid in volutes (pumps must be fully primed); mechanical seals must have a film of liquid between faces for proper operation and to prevent damage.
- 0.3.10 Portable telephones or other electro-magnetic equipment must not be used near the set to avoid corruption of program and unpredictable operation of unit.



### 0.4 CAUTIONS FOR MAINTENANCE

- 0.4.1 READ GENERAL SAFETY INFORMATION 0.0, WARNINGS 0.1 and CAUTIONS 0.2, 0.3 & 0.4
- 0.4.2 The unit should only be operated/maintained by a competent person; *A competent person is someone who is technically competent and familiar with safety practices and the hazards involved.*
- 0.4.3 Where the set is fitted with Building Management Services (BMS) interconnections, notify the appropriate persons before switching OFF for maintenance or adjustments, to avoid unnecessary alarm conditions occurring. WARNING: With pumpset isolator OFF, mains voltage may still be present from BMS system. This constitutes an Electric shock hazard.
- 0.4.4 To prevent seizing, pumpsets must not be left unused for long periods (e.g. 1 week).
- 0.4.5 The pumps must be run regularly to avoid stagnation of water in the pumps/pipework (e.g. daily).
- 0.4.6 Do not vent air from air valves on vessels. These are for adjustment of pre-set cushion pressures. If wrongly adjusted this will lead to incorrect operation of the pumpset and possible damage to pumps, pipework and system components from overheating and over-pressure.
- 0.4.7 Switch OFF pumpset before accessing pumps and/or control panel.

# 1. INSTALLATION INSTRUCTIONS

## FOR VARIMATIC PRESSURE BOOSTER SETS SERIES LG2AV

These instructions are intended for the installer of this pressure booster set. Please follow them carefully.

The unit should only be installed by a competent person; *A competent person is someone who is technically competent and familiar with safety practices and the hazards involved.*

Failure to install the equipment as recommended below could invalidate the warranty provided by AquaTech-Pressmain to the buyer.

### 1.1 ADDITIONAL WARNING

**DO NOT TOUCH ANY LIVE PARTS FOR AT LEAST 5 MINUTES AFTER SWITCHING OFF THE POWER. Failure to observe this will constitute an ELECTRIC SHOCK HAZARD.**

READ GENERAL SAFETY INFORMATION 0.0, WARNINGS 0.1 and CAUTIONS 0.2, 0.3 & 0.4

### 1.2 ADDITIONAL CAUTIONS

- 1.2.1 READ GENERAL SAFETY INFORMATION 0.0, WARNINGS 0.1 and CAUTIONS 0.2, 0.3 & 0.4
- 1.2.2 RCD's/ELCB's are not recommended for use with variable speed drives/motors. Where their use is mandatory use type B RCD's.\*
- 1.2.3 RCD's/ELCB's suitable for use with variable speed drives/motors are not suitable for personnel protection.

\* With the neutral of the supply grounded and the trip limit set at 30mA

### 1.3 PROCEDURE

#### 1.3.1 OFF-LOADING AT SITE

**Do not lift pumpset by pipework.** Lift the pumpset by the container pallet using a pallet/forklift or crane by passing strops underneath the skid using spreader bar. Failure to utilise these facilities could result in damage.

#### 1.3.2 LOCATION

If the set is to be installed in an unheated room, ensure that there is adequate frost protection. Ensure that location for pumpset provides adequate clear space to accommodate unit with reasonable access to all parts; AquaTech-Pressmain recommend a minimum distance of 500mm all round. There must be sufficient room to:-

- fully open control panel door;
- lift and withdraw pumps;
- withdraw diaphragms from vessels.
- remove manifolds from pumps.

If necessary provide overhead lifting eyes for possible future use.

Any Hydraulic Accumulator supplied should be located as near as possible to the pumpset.

**Should any of these location conditions not be satisfied AquaTech-Pressmain reserve the right to charge labour on any warranty work required on the pumpset.**

### 1.3.3 FIXING

Install the set on a flat, even and level surface, where practical on a raised plinth to keep set above damp floor.

It is recommended that the base the pumpset is secured to is at least **5 times** the mass of the pumpset, to help prevent noise and vibration.

Locate unit in position; fit anti-vibration mounts if supplied. If necessary level the base by inserting packing strips adjacent to bolt positions. Firmly attach pumpset to base.

### 1.3.4 PIPEWORK

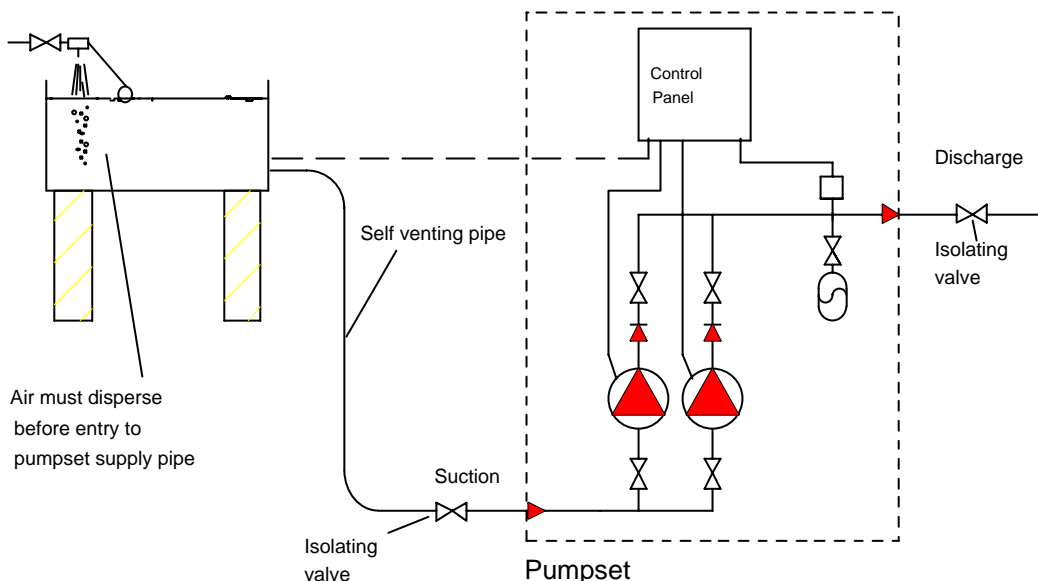

**Fig. 1.1 Pipework**

- 1.3.4.1 Arrange mains water break-tank to ensure fully flooded suction conditions to all pumps within the unit**, unless otherwise specified.
- 1.3.4.2 Arrange the suction pipework to be self venting** between the mains water break-tank and the pumpset suction manifold (see fig.1.1).
- 1.3.4.3 Fit isolating valves to the suction side and discharge side of the pumpset** (see fig.1.1), to enable the pumpset to be isolated from the system for maintenance purposes.
- 1.3.4.4 Under no circumstances fit an extra non-return valve**, to either the suction or the discharge, as it may interfere with the correct operation of the non-return valves already fitted as standard in the pumpset.
- 1.3.4.5 Remove any protective end plugs from suction and discharge pipework on pumpset.**
- 1.3.4.6 Connect site pipework to suction and discharge manifolds**, ensuring adequate support is provided to avoid imposing pipe strain on manifolds. The connecting pipework should not be smaller than that of the pumpset. Where flexible pipe connections are fitted, ensure that the correct distance is allowed between flanges, that the pipework is also aligned axially, and no strain is imposed by the site pipework. (see fig.1.2)
- 1.3.4.7** Where Hydraulic Accumulator(s)/Expansion Vessel(s) are supplied as a loose item, they must be installed/connected correctly before operating the equipment, otherwise serious damage from over-pressure/pump overheating could occur.
- 1.3.4.8** All hydraulic accumulators and expansion vessels fitted to the system must have isolating and drain off valves to enable them to be serviced and removable pipework to enable the diaphragm to be replaced.



### 1.3.6 ELECTRICAL

**WARNING: DO NOT TOUCH ANY LIVE PARTS FOR AT LEAST 5 MINUTES AFTER SWITCHING OFF THE POWER**

READ GENERAL SAFETY INFORMATION 0.0, WARNINGS 0.1 and CAUTIONS 0.2, 0.3 & 0.4

- 1.3.6.1 All wiring must comply with the latest edition of local wiring Regulations.
- 1.3.6.2 **Wear anti-static wrist strap at all times** to avoid static discharge causing problems with the built in electronic program.
- 1.3.6.3 Connect incoming electrical mains supply to identified terminals on isolator IS1 in panel (see fig. 1.3). Ensure voltages and frequency indicated on the wiring diagrams correspond with supply mains data and that the supply fuse type & rating is correct for the total current rating of the equipment.
- 1.3.6.4 Where optional remote fault signal is required, connect volt free terminals in control panel to remote panel. See fig 1.3 and wiring diagram provided.
- 1.3.6.5 Complete any required earth bonding.

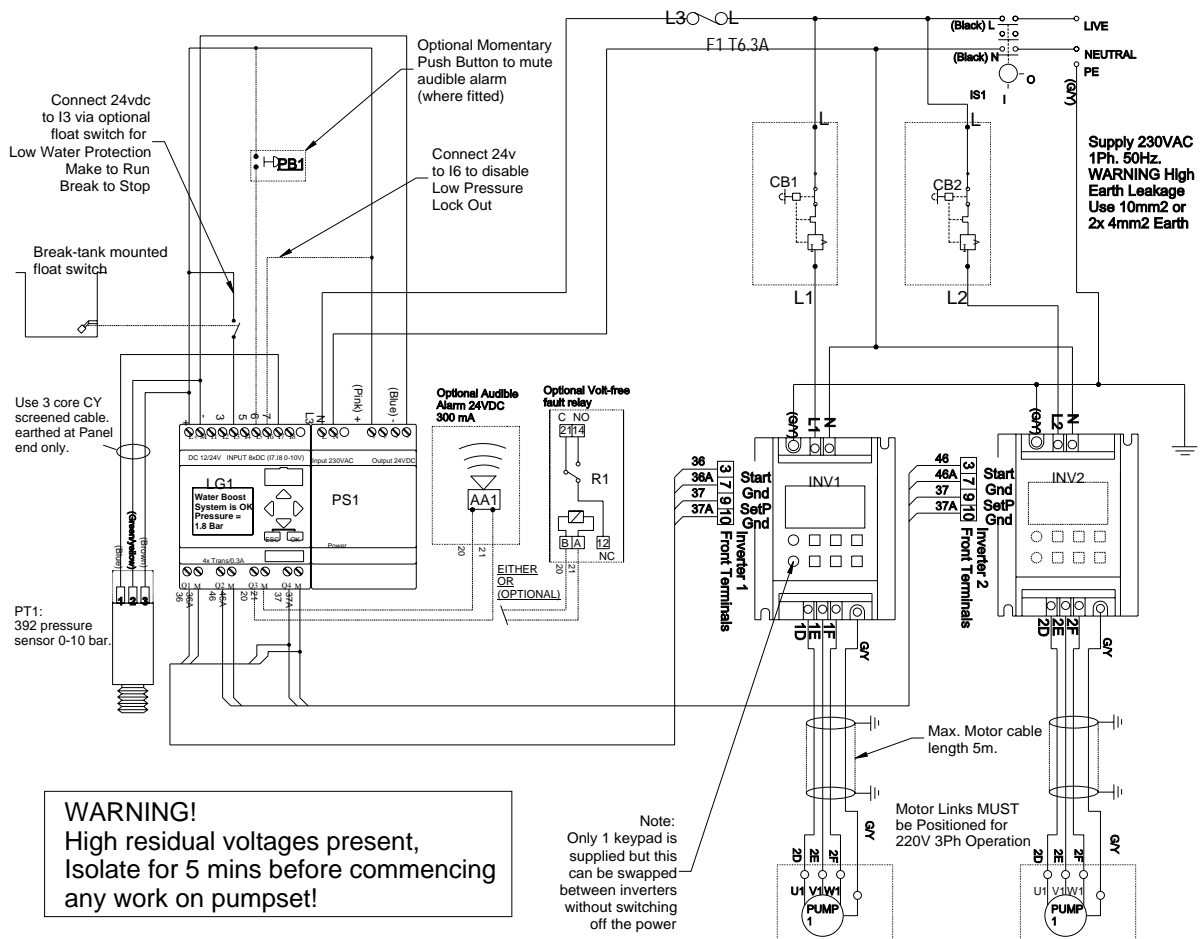

Fig. 1.3 Typical example of electrical connections

## 2. USER INSTRUCTIONS

### 2.1 CUSTOMER ASSURANCE

**AQUATECH-PRESSMAIN ASSURE YOU THAT IF ANY PART OF THIS EQUIPMENT BECOMES DEFECTIVE DUE TO FAULTY MANUFACTURE OR MATERIALS WITHIN 12 MONTHS FROM THE DATE OF INVOICE OR 12 MONTHS FROM DATE OF COMMISSIONING BY AUTHORISED AQUATECH-PRESSMAIN AGENT, THE PART WILL BE REPAIRED OR REPLACED.**

The only conditions are: -

- ◆ The equipment must have been installed, operated and maintained as recommended by **AquaTech-Pressmain Limited**.
- ◆ The equipment must not have been neglected, misused, modified, or used for any other purpose than its original application.
- ◆ The commissioning should be carried out within 6 months of the date of invoice by an authorised **AquaTech-Pressmain Limited** agent.
- ◆ This Assurance does not apply to those items not supplied by us or to defects arising from parts not made or approved by **AquaTech-Pressmain Limited**. The individual manufacturers own policies for dealing with defects will apply.
- ◆ Any part repaired or replaced under these Assurances will be covered for the balance of the appropriate Assurance period.
- ◆ If we have any disagreement about these Assurances which we are unable to resolve we will both abide by the decision of an agreed Arbitrator or, if we are unable to agree, one appointed by the Heating and Ventilating Contractors Association (HVCA) Arbitration Scheme Rules.
- ◆ These Assurances are in addition to, and do not detract from, the contractual rights you have under Statute or at common law.

**For full details please see the AquaTech-Pressmain Ltd. "CONDITIONS OF SALE"**

## 2.2 COMMISSIONING

Whilst this set has been tested in the factory to the required settings (detailed in operating parameters at the back of instruction manual), it is impossible to simulate the actual on-site conditions, especially if they are unusual. Also, the settings may have been disturbed since leaving the factory. Therefore we strongly recommend **the set is commissioned by our authorised agent** who will prepare the set, make any necessary adjustments and leave the set in operational order.

Commissioning also enhances the Warranty (see Customer Assurance)

Prior to requesting an engineer to attend the site for commissioning, the client must ensure that;

- the equipment has been correctly installed;
- a written scheme of examination has been obtained where required under the Pressure Systems Safety Regulations
- any necessary chlorination or other treatment has been completed;
- an adequate water supply and permanent electricity supply are available;
- the pipework etc in the building being served by the pumpset is capable of accepting the generated pressures.

## 2.3 OPERATING INSTRUCTIONS

FOR VARIMATIC PRESSURE BOOSTER SETS with VARIABLE SPEED and SMART RELAY CONTROL, SERIES LG2AV

**These pumpsets are used for increasing the supply pressure of cold potable water and other liquids.**

### WARNING

**DO NOT TOUCH ANY LIVE PARTS FOR AT LEAST 5 MINUTES AFTER SWITCHING OFF THE POWER**

READ GENERAL SAFETY INFORMATION 0.0, WARNINGS 0.1 and CAUTIONS 0.2, 0.3 & 0.4

#### 2.3.1 ADDITIONAL CAUTIONS

- 2.3.1.1 READ GENERAL SAFETY INFORMATION 0.0, WARNINGS 0.1 and CAUTIONS 0.2, 0.3 & 0.4
- 2.3.1.2 The pumpset should be left switched ON for normal operation.
- 2.3.1.3 The Ambient Air Temperature must be within 5 and 30°C

### 2.3.2 NORMAL OPERATION

The Varimatic LG2AV pressure booster set increases and maintains the supply pressure to a preset 'Duty' pressure.

The pumpset consists of two pumps mounted on a base-frame together with associated suction and discharge pipework and valves. The controls are in a set mounted panel.

The control is by a Smart relay controller, with a 4-line digital display showing current system pressure and status.

When switched on the display shows:



Followed by this warning message for 30 seconds:  
(This message appears even if no break tank level switch is fitted)

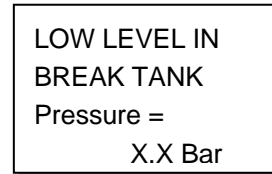

Followed by the system status and pressure:

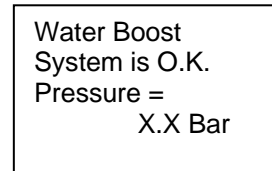

The unit will wait for 10 seconds before starting a pump (if required).

#### Pump Operation

**Model: LG2AV      All pumps variable speed**

Intermittent running duty pump with one assist/support pump meeting demand.

When demand on the system occurs the pressure falls as water from the hydraulic accumulator is discharged into the system. The duty pump then operates at the set duty pressure and will run at variable speed to suit the demand until the demand is satisfied and the accumulator is replenished. Should the duty pump not be sufficient, due to increased demand etc, the support pump will automatically start and run until the demand is satisfied.

#### Duty Pump Rotation

To spread the wear evenly across the pumps the duty pump is automatically rotated each time both pumps stop.

#### Automatic Restart

If there is an interruption in the electrical supply the unit will restart on restoration of the supply.

## TO VIEW THE PARAMETERS

To view the parameters simply press the <DOWN> arrow once while no alarm messages are active. This will take you to the following screen.

SP	18 m
HP	60 m
LP	12 m
SR in	2567 h

SP is the Pressure “Set Point” in metres head (10 metres = 1 Bar)

HP is the “High Pressure” Setting in metres Head

LP is the “Low Pressure” Setting in metres Head

SR is the “Service Reminder” time remaining until the next service is due in Hours

To return to the front screen press <UP>.

### 2.3.3 SYSTEM ALARMS

**Flashing display giving type of fault and a volt free output signal (where fitted)**

Example display:- Signifies an alarm has been triggered:

SYSTEM ALARM Info follows Pressure = X.X Bar
---

System Alarm	Cause	Check
System Alarm Info Follows	Signifies an alarm has been triggered	Note all following active alarm conditions displayed. Each active alarm will be shown in turn.
High or Low pressure	System pressure at/above high pressure setting & delay timer expired	Pressure vessel air charge wrong? Or insufficient expansion capacity? Pump(s) left in Hand?
High or Low pressure	System pressure at/below low pressure setting & delay timer expired	Pressure vessel air charge wrong? Or water usage exceeds design capacity? Pump(s) switched Off or Tripped? Check electrical supply is within tolerance, or missing phase? Pump seized? motor failed? Variable speed drive/inverter trip? Motor thermistor overheated?
Low Level in break tank	Water level below low water alarm float switch (30 second delay on automatic restart, after restoration of water level).	Break tank float valve stuck closed? Or output of pumpset exceeds mains water supply into break tank? Mains water interruption to break tank?
Low pressure lockout/ vent pumps	System pressure remained at or below low pressure setting for duration of low pressure delay timer, and lock out protection is invoked.	Pumps are air locked and need venting? Or running off end of curve due to demand beyond design limit? Pump(s) switched Off or Tripped?
Service Due	Your equipment needs to be serviced	Please contact the AquaTech-Pressmain service department for more details.
Alarm Muted	If your unit has the optional audible alarm this can be muted using the Mute Button.	

### 2.3.4 PUMP FAULTS

**WARNING! When accessing the control panel take care not to touch ANY LIVE PARTS. These should be left to discharge for at least 5 minutes after switching off the power.**

#### LG2AV: Fault Resetting

**Overload fault** Isolate the pumpset hydraulically at the discharge side, Switch off isolator, open control panel. Look for tripped motor circuit breaker MCB1, MCB2, etc and turn the tripped MCB fully off and then fully on to reset the overload. Close panel door and follow instructions below to bring pumpset back online.

**Inverter fault** Isolate the pumpset hydraulically at the discharge side, switch off pumpset isolator for 1 minute. Switch on the isolator again to reset the inverter. After the pumpset has completed its power up procedure SLOWLY open the discharge valve to allow the system to refill. WARNING; opening the discharge valve too quickly could cause hydraulic shock to occur and cause damage to the system.

#### Inverter/Pump Faults and Alarms

Where appropriate a fault is indicated by the status LED on the front of the inverter.

Inverter LED status: -	Meaning: -
LED OFF	Inverter Off / No Supply
1000ms ON / 1000ms OFF	Inverter ON / Ready
Steadily ON	Inverter Running OK
500ms ON / 200ms OFF	General Warning
100ms ON / 100ms OFF	Fault Condition

If an inverter LED is showing a General Warning or Fault Condition, move the Basic Operator Panel (BOP) onto this drive and read off a fault or alarm code if shown.

Note: The BOP can be fitted to and removed from the inverter whilst power is applied.

If a **Fault** is triggered the inverter switches off and the fault code will appear on the display. To reset a fault: Cycle the power to the drive or Press the function button (FN) on the BOP

FAULT CODE	DESCRIPTION	CAUSE / REMEDY
F0001	Over current	Motor Lead short circuit or Earth Fault or pump overloaded
F0002	Over voltage	Main supply voltage too high / Check supply
F0003	Under voltage	Main supply voltage too low / Mains failure / Check supply
F0004	Inverter Over Temperature	Inverter overloaded / Ventilation inadequate / Ambient temperature too high
F0005	Inverter $I^2t$	Inverter overloaded / motor power exceeds inverter power
F0011	Motor Over Temperature $I^2t$	Pump overloaded / excessive demand
F0051	Parameter EEPROM Fault	Phone AquaTech-Pressmain service for assistance
F0052	Power Stack Fault	
F0060	Asic Timeout	
F0072	USS Setpoint Fault	
F0085	External Fault	

If an **alarm** is triggered the appropriate code will appear on the display the inverter will remain running but may have a reduced output.

ALARM CODE	DESCRIPTION	CAUSE / REMEDY
A0501	Current Limit	Motor power does not correspond to inverter power / Earth faults
A0502	Over voltage Limit	Over voltage limit reached / check supply
A0503	Under voltage Limit	Under voltage limit reached / check supply
A0505	Inverter I <sup>2</sup> t	Inverter overloaded / inadequate ventilation
A0511	Motor Over Temperature I <sup>2</sup> t	Pump overloaded / excessive demand
A0910	Vdc-max controller de-activated	Phone AquaTech-Pressmain service for assistance
A0911	Vdc-max controller active	
A0920	ADC parameters not set properly	
A0923	Both Jog left and Jog right have been requested	

## VENTING PUMPS

To vent pumps:

Isolate pumpset from system by closing a common discharge valve.

### ISOLATE control panel

Undo air vent screw on each pump body until all the air is released

Re-tighten screws

Switch ON panel isolator.

After pumpset has initialised, slowly open discharge valve to bring the pumpset back online.

Note: Failure to close the discharge valve, or reopening it too quickly could cause damage to the system.

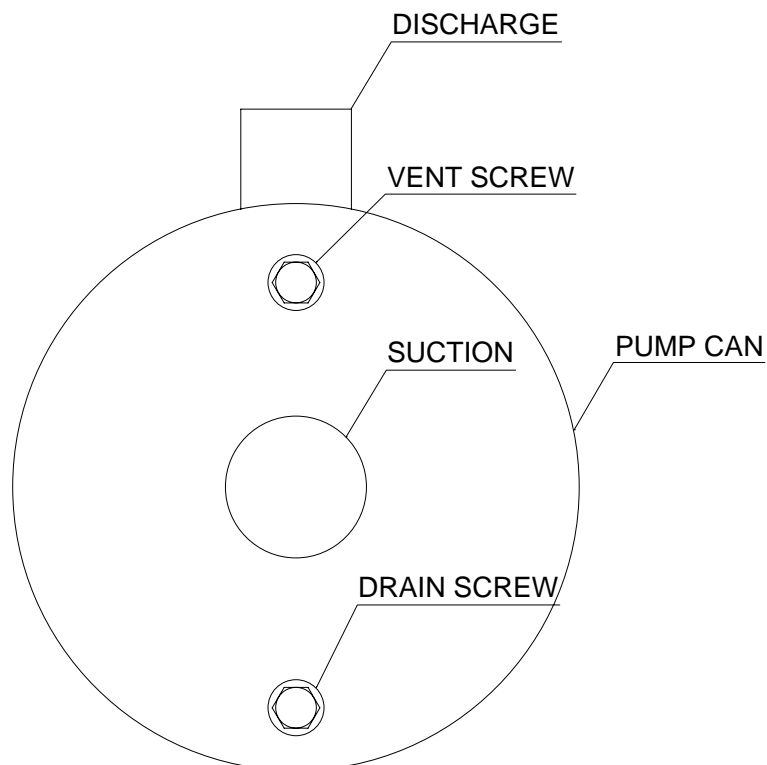

Fig 2.1 Venting Pumps

## **REMOTE SIGNAL**

**-Optional volt free contact in control panel (see fig 1.3):**

Low Pressure / Low Pressure Lock-out

Low Water in break-tank (if optional level switch fitted)

High pressure

## **REMOTE ALARM PANEL** if requested

Light indicating a fault condition is present, and an optional audible alarm, in separate panel wired to terminals inside pumpset control panel.

**If a problem persists contact AQUATECH-PRESSMAIN LIMITED service department on quoting the serial number WN:\_\_\_\_\_ (on control panel fascia)**

## 2.4 MAINTENANCE INSTRUCTIONS FOR VARIMATIC LG2AV

### WARNING: DO NOT TOUCH ANY LIVE PARTS FOR AT LEAST 5 MINUTES AFTER SWITCHING OFF

#### 2.4.1. ADDITIONAL CAUTIONS

2.4.1.1 READ GENERAL SAFETY INFORMATION 0.0, WARNINGS 0.1 and CAUTIONS 0.2, 0.3 & 0.4

#### 2.4.2 PROCEDURE

Every 6 months the pumpset should be maintained by authorised AquaTech-Pressmain service agents - see Servicing (Section 3.)

##### Pump Lubrication

Pumps require no lubrication as the impeller shafts are carried on the motor bearings.

##### Motor Lubrication

Motor bearings are normally sealed and require no lubrication. However should a motor have a grease point use good quality grease, and completely renew every two years.

##### Expansion, Control and Hydro Accumulator vessels

1. **Air Charge Pressure.** The correct charge pressure provides reliable operation of the system and a prolonged lifetime of the diaphragm. This should be checked regularly. To adjust: isolate the vessel from the system and release pressure on water side by opening the drain cock disposing of the water-mix in the appropriate manner. The water inside the bladder will be pushed back by the air charge pressure. Remove cap on the filling valve, set air charge pressure refilling using dry air or nitrogen. Screw cap firmly on filling valve. Close the drain cock and open water connection to the system.
2. **Replacement of the diaphragm** (except for 8l vessels where the complete vessel is replaced). Isolate vessel from the system and drain water from vessel using drain cock disposing of the water-mix in the appropriate manner. Release air charge. Remove water connection flange A. Release diaphragm support B by removing cap F and nut C on dished end D. Remove diaphragm E from inside the bottom opening.

Check vessel for dirt, corrosion etc., remove or flush with water. The diaphragms are not oil resistant and oily liquids must not be used to protect the inside surfaces of tanks against corrosion. The vessel should be dry when replacing diaphragm.

Put support B in new diaphragm and pass a flexible cord through the hole in support B, securing it on the underside. Roll up diaphragm in the longitudinal axis and pull the diaphragm by means of the cord into the vessel as far as the fixing opening in the top, then remove rope. Secure support B by fitting washer U and nut C. Fit cap F on top of B and close vessel by replacing flange A.

Recharge with dry air or nitrogen as above. Check vessel for leaks and reconnect to the system.

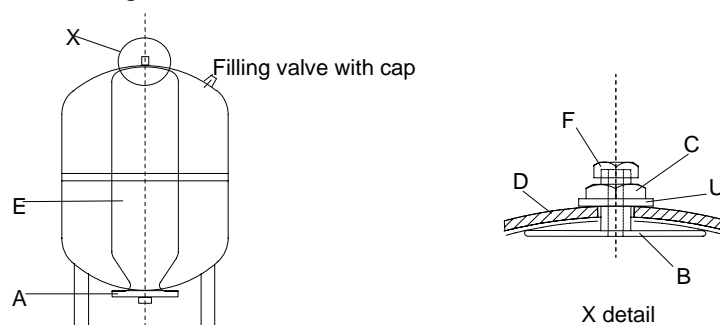

LEAVE SET WITH ALL PUMPS SWITCHED ON , AND THE MAINS SUPPLY SWITCHED ON.

## 3. SERVICING

### 3.1 MAINTENANCE AND CARE OF YOUR EQUIPMENT

The AquaTech-Pressmain equipment that is described in this instruction booklet has been manufactured and tested to the highest standards of design and quality. It will give trouble free operation over many years provided it is maintained regularly from when it is commissioned. To keep it operating efficiently in a safe, economical and environmentally friendly condition, regular maintenance is an essential part.

AquaTech-Pressmain Limited along with its' sister company, and fellow AGM Group member, Acorn Pressurisation Services Ltd are the official providers of commissioning and maintenance services. (see below).

Several companies operating under the Aquatronic Group Management structure are available to fulfil a wide range of servicing and maintenance requirements, as detailed below.

### 3.2 LEGAL REQUIREMENTS

Hydraulic Accumulators/Expansion Vessels installed as part of/in conjunction with this equipment, with Pressure x Volume above 250 Bar-litres, require formal inspection in accordance with a "Written Scheme of Examination". This is a Legal Requirement on the part of the Owner/User under the "Pressure Systems Safety Regulations" (PSSR). A "Written Scheme" and regular inspection can be provided by either Acorn Pressurisation Services (combined maintenance and inspection) or ESIS Ltd (inspection only), see details below.

#### Plant Servicing & Inspection



**ACORN PRESSURISATION SERVICES LIMITED,**  
**AGM House, Essex, CO6 1GT. Ph: 01206 215151**  
**130 Princess Rd, Manchester, M16 7BY. 0161 226 4727**

Acorn provides maintenance and installation of all types of packaged water pumping equipment for building services. Its specialist fields are Pressure booster equipment and sealed systems for heating and chilled water distribution systems.

Regular servicing of any plant for essential services is vital because wear and tear are very gradual processes. With preventative maintenance, the costs are small and benefits in reliability, safety and economy can be significant. Acorn Pressurisation Services Ltd can provide a complete package of schemes for preventative maintenance on all AquaTech-Pressmain and other makes of equipment.

#### Pressure Vessel Inspection



**ESIS ENGINEERING SAFETY & INSPECTION SERVICES LTD,**  
**AGM House, London Rd, Copford, Colchester, Essex, CO6 1GT.**  
**Phone: 01206 215141 Fax: 01206 215142**

Under the Pressure Systems Safety Regulations, expansion vessels and hydraulic accumulators, generally 250 bar-litres and greater, and protection devices, require a Written Scheme of Examination before they can be operated. ESIS Inspection and Insurance Services Limited specifications can provide the means to comply with these regulations. These services can be extended to cover other units e.g. air pressure receivers etc.

#### Pump Repairs and Overhauls



**AGM PUMP SERVICES LIMITED,**  
**AGM House, London Rd., Copford, Colchester, Essex CO6 1GT**  
**Phone: 01206 215111 Fax: 01206 215112**

AGM Pump Services Limited can provide a full range of overhaul and replacement facilities for pumps on both AquaTech-Pressmain and other makes of equipment. Drawing on extensive expertise, it can carry out the full overhaul of pumps, including the removal and refitting of the pumps to site using its skilled technicians. It can also provide a full workshop investigation of any given pump.

### 3.3 SERVICE CONTACTS

**For service during warranty period contact: AQUATECH-PRESSMAIN Service Department**  
**Head Office Tel: 01206 215121 Manchester Office Tel: 0161 226 4727**

**For regular servicing, contact their service agents: ACORN PRESSURISATION SERVICES LTD**  
**Head Office Tel: 01206 215151 Manchester Office Tel: 0161 226 4727**

who will be pleased to give you expert advice on this or any other servicing matter.

## 4. DISPOSAL

Disposal of this product or parts of it must be carried out in accordance with the following guidelines:

Use the local public or private recycling/waste collection service.

In case such a recycling/waste collection service does not exist or cannot handle the materials used in this product, please deliver the product or any hazardous material from it to your nearest AquaTech-Pressmain office.

### **EC Declaration of Conformity**

We, Aquatech-Pressmain Limited, declare this Pressure Equipment Assembly:

**PRESSURE BOOSTER SET  
MODEL : Varimatic LG2**

Complies with the following standards:

**BS EN 60204-1:2006  
EN61000-6-3:2001, EN61000-6-1:2001**

and meets the requirements of EEC Directives:

**Pressure Equipment Directive 97/23/EC (PED)  
Low Voltage Directive 73/23/EEC and 93/68/EEC  
Electro Magnetic Compatability Directive 89/336/EEC with amendments  
92/31/EEC.**

**PED Conformity Assessment Modules : B + D  
Notified Body : BSI Product Services,  
Maylands Avenue  
Hemel Hempstead  
Hertfordshire  
HP2 4SQ**

**Type Examination Certificate Ref. CE95657**



30.07.2005

I.D.Taylor, I.Eng, MIET, Director, AquaTech-Pressmain Limited.

**AquaTech-Pressmain Limited**  
AGM House, London Rd, Copford, Colchester, Essex CO6 1GT UK  
Telephone: 01206 215121 Fax: 01206 215131

# OPERATING PARAMETERS

**SERIAL No.** ..... **MODEL**.....

THE SERIAL & MODEL NUMBERS MUST BE QUOTED WHEN REQUESTING ASSISTANCE

## ELECTRICAL DATA:

Supply **240** volts **1** Ph **50** Hz

Minimum Mains Supply Size ..... Amps

Max. pumpset loading: ..... Kw Method of starting: Variable Speed Drive

**NOISE LEVEL:** less than 70 db(A) unless otherwise stated .....

**NOMINAL FLOW RATE:** ..... litres/sec

## PRESSURE SETTINGS:

### AS FACTORY SET

	bar		secs
Pump Duty pressure	.....		
Hyd.Accumulator:	.....		
Pump closed valve press.	.....		
		Minimum run time	30
Low pressure	.....	Low pressure delay	10
High pressure	.....	High pressure delay	10

AMENDED AT COMMISSIONING	
bar	
.....	
.....	
.....	
.....	
.....	
.....	

❖ On commissioning it may be found necessary to modify these settings. Providing this information is left with the equipment, the figures will be updated by the commissioning engineer.

Updated by commissioning engineer ..... Date .....