



AquaTech Pressmain

INSTRUCTIONS FOR

0. GENERAL SAFETY INFORMATION, WARNINGS & CAUTIONS
1. INSTALLATION
2. THE USER
3. SERVICING
4. DISPOSAL

MICROMATIC HM2 SERIES COLD WATER PRESSURE BOOSTER SETS WITH MPC CONTROL

MODEL: HM2ET



WRAS
APPROVED
PRODUCT







CE

ISSUE: 14 29/03/10

Head Office: AGM House, London Rd, Copford, Colchester, Essex CO6 1GT UK
Tel: 01206 215121 Fax: 01206 215131

Manchester Office: Dolphin House, 130 Princess Road, Manchester M16 7BY
Tel: 0161 226 4727 Fax: 0161 226 5848

CONTENTS

| | | | |
|---|---|--|-----------|
|  | 0.0 GENERAL SAFETY INFORMATION |  | 4 |
| 0.1 |  WARNINGS | | 4 |
| 0.2 |  CAUTIONS FOR INSTALLATION | | 5 |
| 0.3 |  CAUTIONS FOR OPERATION/USER | | 6 |
| 0.4 |  CAUTIONS FOR MAINTENANCE | | 7 |
| 1. | INSTALLATION INSTRUCTIONS | | 8 |
| 1.1 | GENERAL | | 8 |
| 1.2 | ADDITIONAL CAUTIONS | | 8 |
| 1.3 | PROCEDURE | | 8 |
| 1.3.1 | OFF-LOADING AT SITE | | 8 |
| 1.3.2 | LOCATION | | 8 |
| 1.3.3 | FIXING | | 8 |
| 1.3.4 | PIPEWORK | | 9 |
| 1.3.5 | EXPANSION, CONTROL and HYDRAULIC ACCUMULATOR VESSELS | | 10 |
| 1.3.6 | ELECTRICAL | | 11 |
| 2. | USER INSTRUCTIONS | | 12 |
| 2.1 | CUSTOMER ASSURANCE | | 12 |
| 2.2 | COMMISSIONING | | 13 |
| 2.3 | OPERATING INSTRUCTIONS | | 13 |
| 2.3.1 | ADDITIONAL CAUTIONS | | 13 |
| 2.3.2 | NORMAL OPERATION | | 13 |
| | PUMP OPERATION | | 13 |
| 2.3.3 | SYSTEM ALARMS | | 14 |
| | REMOTE SIGNAL | | 14 |
| | VENTING PUMPS | | 15 |
| 2.4 | MAINTENANCE INSTRUCTIONS | | 16 |
| | 2.4.1. ADDITIONAL CAUTIONS | | 16 |
| | 2.4.2. PROCEDURE | | 16 |
| 3. | SERVICING | | 17 |
| 3.1 | MAINTENANCE AND CARE OF YOUR EQUIPMENT | | 17 |
| 3.2 | LEGAL REQUIREMENTS | | 17 |

| | |
|---|-----------|
| 3.3 SERVICE CONTACTS | 17 |
| 4. DISPOSAL | 19 |
| <u>EC DECLARATION OF CONFORMITY</u>..... | 19 |
| OPERATING PARAMETERS | 20 |

0.0 GENERAL SAFETY INFORMATION

- These instructions are intended for the installer/operator/user/maintenance of this equipment and must be kept with the equipment, for the life of the equipment and made available to all persons. Please read GENERAL SAFETY INFORMATION 0.0, WARNINGS 0.1 and CAUTIONS 0.2, 0.3 & 0.4 before doing anything else, and then follow them carefully.
- The unit must only be installed/operated/used/maintained by a competent person; *A competent person is someone who is technically competent and familiar with safety practices and the hazards involved.*
- Hydraulic Accumulators/Expansion Vessels installed as part of/in conjunction with this equipment, with Pressure x Volume above 250 Bar-litres, require regular formal inspection by a *competent person*. This is a Legal Requirement under the “Pressure Systems Safety Regulations” (PSSR) and the Owner/User should be made aware of their responsibility for this. (see section 3. Servicing).
- Failure to install/operate/use/maintain the equipment as recommended below could cause damage to the equipment any anything subsequently connected to it, and invalidate the warranty provided by AquaTech-Pressmain to the buyer.
- Any damage caused to the equipment by misapplication, mishandling or misuse could lead to risk of **Electrocution, Burns, Fire, Flooding or injury to people or property** dependent upon the circumstances involved.
- This equipment contains moving/rotating parts that must remain guarded. Removal of or missing guards could lead to serious personal injury.
- This equipment automatically restarts after a power interruption.
- We accept no responsibility or liability for any consequences or damage/losses due to misapplication, mishandling or misuse of the equipment.
- It should be noted that the assembly of pressure equipment on site under the responsibility of the user (or his representative) is not subject to the Pressure Equipment Directive 97/23/EC. (National legislation covering assembly on site will apply)
- The latest version of this instruction manual with up to date safety information can be downloaded from our website at www.aquatechpressmain.co.uk

0.1 WARNINGS

- 0.1.1 Do not touch any live parts for at least 5 minutes after switching off the electricity supply. Failure to observe this will constitute a severe Electric shock and/or Burns hazard and may be lethal.**
- 0.1.2 The equipment is only suitable for earth referenced supplies and must be permanently earthed to avoid Electric shock hazard.**
- 0.1.3 With equipment isolator OFF, mains voltage may still be present from BMS system. This constitutes an Electric shock hazard.**
- 0.1.4 Emergency stop button does not remove dangerous voltages from control panel/pump motor assemblies. This constitutes an Electric shock hazard.**
- 0.1.5 Metal parts (e.g. heat sinks) may reach temperatures of 90 degrees centigrade and will constitute a Burns hazard.**
- 0.1.6 Some equipment is designed to operate with liquid temperatures up to 150 degrees centigrade and will constitute a Burns/scalding hazard.**
- 0.1.7 The equipment must not be pressurised beyond the maximum working pressure as stated on pumps/pipework/vessels/control panel otherwise serious mechanical damage/destruction could occur causing injury to people or property.**

- 0.1.8** The equipment must not be heated/chilled beyond the maximum/minimum working temperature as stated on pumps/pipework/vessels/control panel otherwise serious mechanical damage/destruction could occur causing injury to people or property.
- 0.1.9** Any damage to equipment, pumpset, vessels, pipework or system components caused by misapplication, mishandling or misuse could lead to Electric shock hazard, Burns hazard, Fire hazard, Flooding hazard or cause injury to people or property.
- 0.1.10** This equipment may contain moving/rotating parts that must remain guarded. Removal of or missing guards could lead to serious personal injury.
- 0.1.11** Pressure vessels must never be disassembled whilst in use, they contain high pressure air/gas charge which could cause injury to people or property.
- 0.1.12** Pump motors with lifting eyes; the lifting eyes are only suitable for lifting motors NOT the entire pump assembly. This could cause injury to people or property.
- 0.1.13** Ensure the base/foundation/plinth/wall to which the equipment is to be attached is sufficiently strong enough to carry the entire mass of the equipment including the water that it will contain under worst-case fault conditions. E.g. fully saturated pressure vessel with no air charge, break tank full to overflowing, etc. Failure to observe this could cause serious mechanical damage/destruction resulting in injury to people or property.



0.2 CAUTIONS FOR INSTALLATION

- 0.2.1** READ GENERAL SAFETY INFORMATION 0.0, WARNINGS 0.1 and CAUTIONS 0.2, 0.3 & 0.4
- 0.2.2** The unit should only be installed/operated by a competent person; *A competent person is someone who is technically competent and familiar with safety practices and the hazards involved.*
- 0.2.3** Do not lift the pumpset by pipework. Lift the pumpset by the container pallet using a pallet/forklift or crane by passing strops underneath the skid using a spreader bar. Failure to utilise these facilities will result in damage to the pumpset.
- 0.2.4** Store in a dry place to avoid damp conditions deteriorating the equipment.
- 0.2.5** Protect against dirt, damage and frost. It is absolutely essential that no foreign matter such as pipe thread swarf, welding slag, grit or stones are allowed to enter the set. Debris of this type can cause severe damage to the mechanical seals, diaphragms and impeller. Frost/freezing will damage pumps/pipework and control panel components.
- 0.2.6** The equipment is only suitable for installation in a clean, dust free indoor environment, with adequate protection from heat and frost, and sufficient ventilation to ensure cooling of the motors. Ambient air temperature should be between 5 and 40 degrees centigrade, non-condensating. Operation outside of these conditions could seriously damage the equipment.
- 0.2.7** If the equipment were to be stored or taken out of service for a period of time (e.g. 1 week or more), then we would recommend draining the equipment of all water/liquid (with due regard to any local regulations) to prevent frost damage to components. When restarting is required we would recommend commissioning by our authorised service agent.
- 0.2.8** Ensure the base/foundation/plinth/wall to which the equipment is to be attached has sufficient mass compared to the equipment, in order to avoid noise/vibration transmission. E.g. the mass of the base should be at least five times the mass of the equipment.
- 0.2.9** Ensure the electrical supply is the correct voltage, current, frequency and type for the equipment supplied and that suitable circuit protection equipment is installed in the supply. Incorrect electrical installation could be an electric shock/burns/fire hazard.
- 0.2.10** When accessing the control panel to make electrical connections adopt anti-static procedures e.g. wear anti-static earthed wristband, to avoid risk of damaging the controller.
- 0.2.11** All products that are packaged to include Pressure vessel(s)/Hydraulic Accumulator(s)/Expansion Vessel(s) are classed as "Assemblies" under the Pressure Equipment Directive (PED). Where units are despatched with "Loose" vessel(s) for assembly on site it is absolutely essential that they be installed as detailed in the instructions using the

fittings provided where appropriate. Failure to observe this will nullify compliance with the PED and may present a safety hazard. Your warranty may also be affected.

- 0.2.12** Where Hydraulic Accumulator(s)/Expansion Vessel(s) are supplied as a loose item, they must be installed/connected correctly before operating the equipment, otherwise serious damage from over-pressure/pump overheating could occur.
- 0.2.13** Do not operate this equipment/pumpset prior to commissioning (section 2.2) This could cause irreparable damage to equipment/pumpset/pipework/system components.
- 0.2.14** Isolate the equipment/pumpset before pressure testing system. Excess pressure could irreparably damage the pressure transducer, pressure switches (where fitted) and the diaphragms of pressure vessel/hydraulic accumulators.
- 0.2.15** It is the installers' responsibility to ensure subsequent pipework etc can accept the pressures generated by the equipment/pumpset and to install an overpressure safety device into the system with due respect to the suction pressure present on the pumpset, the pump closed valve pressure stated on the pump, the maximum working pressure stated on any of the attached pressure vessels and any other device connected to the system e.g. boilers, calorifiers etc.
- 0.2.16** When chlorination of the system is carried out, ensure that any residual chlorine is removed by thorough flushing as detailed in the HSE approved code of practice L8, to avoid damaging the equipment/pumpset. The normal level of chlorination is up to 2 parts per million (ppm), but shock dosing for sterilization purposes, at 25-50 ppm for 24-48 hours is acceptable as long as all chlorine is removed once the process is complete. Chlorination beyond these limits could seriously damage pumpset components and WILL NOT be covered by the warranty.
- 0.2.17** The installer/user is responsible for the installation of the correct earthing and protection according to valid national and local standards. All operations must be carried out by a suitably qualified person.
- 0.2.18** The equipment is only suitable for earth referenced supplies and must be permanently earthed to avoid electric shock hazard.
- 0.2.19** The equipment must be permanently earthed with appropriate sized Earthing.
- 0.2.20** Never perform high voltage resistance tests on control panels, variable speed drives/motors without first disconnecting the panel/drive/motor from the circuit being tested as this will damage the built in electronic components.
- 0.2.21** Metal parts (e.g. heat sinks) may reach temperatures of 90 degrees centigrade.
- 0.2.22** EMC - With respect to BS EN61000-3-2 this equipment is defined as 'professional equipment' and therefore the installer/user may need to seek permission from the supply utility to connect this equipment to the public low voltage mains supply.
- 0.2.23** Where "Expansion vessels" are used on Domestic hot water systems (DHWS) or LTHW heating system pressurisation units, the temperature of the fluid returning to the vessels should not exceed 70 degrees Centigrade as this could damage the vessel diaphragm. Where the temperature exceeds 70C an intermediate cooling vessel should be fitted.
- 0.2.24** Drain cocks/valves and air bleed screws must not be left open as this could cause flooding.



0.3 CAUTIONS FOR OPERATION/USER

- 0.3.1** READ GENERAL SAFETY INFORMATION 0.0, WARNINGS 0.1 and CAUTIONS 0.2, 0.3 & 0.4
- 0.3.2** The unit should only be operated/used by a competent person; *A competent person is someone who is technically competent and familiar with safety practices and the hazards involved.*
- 0.3.3** The Owner/User of this equipment has a Legal Responsibility to ensure that it is subject to regular formal inspections. See Section 3. Servicing, for details.
- 0.3.4** Where Hydraulic Accumulator(s)/Expansion Vessel(s) are supplied as a loose item, they must be installed/connected correctly before operating the equipment, otherwise serious damage from over-pressure could occur.
- 0.3.5** The set must not be run until commissioned by an authorised AquaTech-Pressmain agent, this could irreparably damage the pump set and/or system components/pipework connected to it.
- 0.3.6** The pumpset should be left switched ON with the pumps switched to AUTO for normal operation.

- 0.3.7 The pumpset should not be left in “Hand” operation for more than 1 minute. This could lead to severe damage of pumpset components and/or pipework system from over-pressure and/or overheating.
- 0.3.8 Ensure pumpset has an adequate water supply at all times to prevent dry running causing pump seal damage and water leakage.
- 0.3.9 Do not attempt to start pumps without liquid in volutes (pumps must be fully primed); mechanical seals must have a film of liquid between faces for proper operation and to prevent damage.
- 0.3.10 Portable telephones or other electro-magnetic equipment must not be used near the set to avoid corruption of program and unpredictable operation of unit.



0.4 CAUTIONS FOR MAINTENANCE

- 0.4.1 READ GENERAL SAFETY INFORMATION 0.0, WARNINGS 0.1 and CAUTIONS 0.2, 0.3 & 0.4
- 0.4.2 The unit should only be operated/maintained by a competent person; *A competent person is someone who is technically competent and familiar with safety practices and the hazards involved.*
- 0.4.3 Where the set is fitted with Building Management Services (BMS) interconnections, notify the appropriate persons before switching OFF for maintenance or adjustments, to avoid unnecessary alarm conditions occurring. WARNING: With pumpset isolator OFF, mains voltage may still be present from BMS system. This constitutes an Electric shock hazard.
- 0.4.4 To prevent seizing, pumpsets must not be left unused for long periods (e.g. 1 week).
- 0.4.5 The pumps must be run regularly to avoid stagnation of water in the pumps/pipework (e.g. daily).
- 0.4.6 Do not vent air from air valves on vessels. These are for adjustment of pre-set cushion pressures. If wrongly adjusted this will lead to incorrect operation of the pumpset and possible damage to pumps, pipework and system components from overheating and over-pressure.
- 0.4.7 Switch OFF pumpset before accessing pumps and/or control panel.

1. INSTALLATION INSTRUCTIONS FOR MICROMATIC PRESSURE BOOSTER SETS SERIES HM2ET

1.1 GENERAL

These instructions are intended for the installer of this pressure booster set. Please follow them carefully.

The unit should only be installed by a competent person. *A competent person is someone who is technically competent and familiar with safety practices and the hazards involved.*

Failure to install the equipment as recommended below could invalidate the warranty provided by AquaTech Limited to the buyer.

READ GENERAL SAFETY INFORMATION 0.0, WARNINGS 0.1 and CAUTIONS 0.2, 0.3 & 0.4

1.2 ADDITIONAL CAUTIONS

1.2.1 READ GENERAL SAFETY INFORMATION 0.0, WARNINGS 0.1 and CAUTIONS 0.2, 0.3 & 0.4

1.3 PROCEDURE

1.3.1 OFF-LOADING AT SITE

Do not lift pumpset by pipework. Lift the pumpset by the container pallet using a pallet/forklift or crane by passing strops underneath the skid using spreader bar. Failure to utilise these facilities could result in damage.

1.3.2 LOCATION

If the set is to be installed in an unheated room, ensure that there is adequate frost protection. Ensure that location for pumpset provides adequate clear space to accommodate unit with reasonable access to all parts; AquaTech recommend a minimum distance of 500mm all round. There must be sufficient room to:-

- fully open control panel door;
- lift and withdraw pumps;
- withdraw diaphragms from vessels.
- remove manifolds from pumps.

If necessary provide overhead lifting eyes for possible future use.

Any Hydraulic Accumulator supplied should be located as near as possible to the discharge side of the pumpset.

Should any of these location conditions not be satisfied AquaTech-Pressmain Limited reserve the right to charge labour on any warranty work required on the pumpset.

1.3.3 FIXING

Install the set on a flat, even and level surface, where practical on a raised plinth to keep set above damp floor.

Locate unit in position; fit anti-vibration mounts if supplied. If necessary level the base by inserting packing strips adjacent to bolt positions. Firmly attach pumpset to base.

1.3.4 PIPEWORK

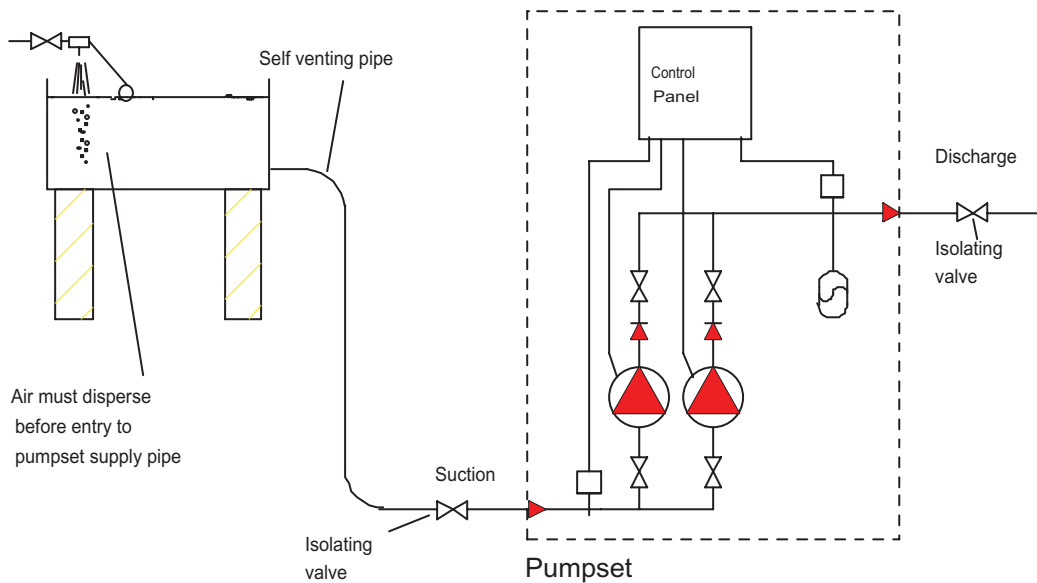

Fig. 1.1 Pipework

- 1.3.4.1 **Arrange mains water break tank to ensure fully flooded suction conditions to all pumps within the unit**, unless otherwise specified.
- 1.3.4.2 **Arrange the suction pipework to be self venting** between the mains water break tank and the pumpset suction manifold (see fig.1.1).
- 1.3.4.3 **Fit isolating valves to the suction side and discharge side of the pumpset** (see fig.1.1), to enable the pumpset to be isolated from the system for maintenance purposes.
- 1.3.4.4 **Under no circumstances fit an extra non-return valve**, to either the suction or the discharge, as it may interfere with the correct operation of the non-return valves already fitted as standard in the pumpset.
- 1.3.4.5 **Remove any protective end plugs from suction and discharge pipework on pumpset.**
- 1.3.4.6 Where Hydraulic Accumulator(s)/Expansion Vessel(s) are supplied as a loose item, they must be installed/connected correctly before operating the equipment, otherwise serious damage from over-pressure/pump overheating could occur (for mounting see 1.3.5).
- 1.3.4.7 **Connect site pipework to suction and discharge manifolds**, ensuring adequate support is provided to avoid imposing pipe strain on manifolds. The connecting pipework should not be smaller than that of the pumpset. Where flexible pipe connections are fitted, ensure that the correct distance is allowed between flanges, that the pipework is also aligned axially, and no strain is imposed by the site pipework. (see fig.1.2)

| MAX PERMISSIBLE MOVEMENT | | | | | |
|--------------------------|------------------|-----------------|-----------------|------------|----------------------|
| BORE OD (mm) | NOM. Length (mm) | AXIAL EXTN (mm) | AXIAL COMP (mm) | SHEAR (mm) | ANGULAR MOVEMENT DEG |
| 32 | 130 | 4 | 8 | 8 | 15 |
| 40 | 130 | 4 | 8 | 8 | 15 |
| 50 | 130 | 5 | 8 | 8 | 15 |
| 65 | 130 | 6 | 12 | 10 | 15 |
| 80 | 130 | 6 | 12 | 10 | 15 |
| 100 | 130 | 10 | 18 | 12 | 15 |
| 125 | 130 | 10 | 18 | 12 | 15 |
| 150 | 130 | 10 | 18 | 12 | 15 |

Compression

Extension

Shear

Angulation

Fig. 1.2 Flexible connections

1.3.5 EXPANSION, CONTROL and HYDRAULIC ACCUMULATOR VESSELS

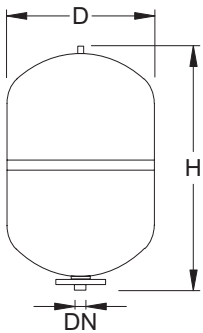

8 RS

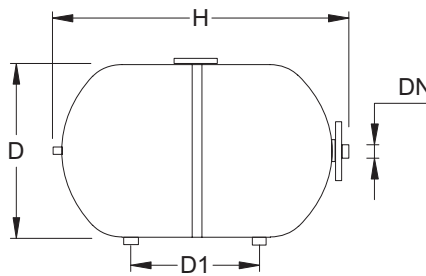

25 HR

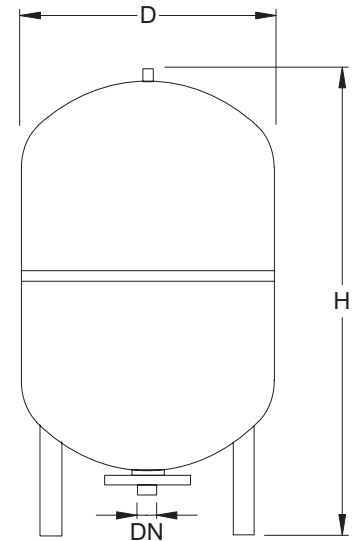

60 VR - 500 VR

| Type | 8 RS | 25 HR | 60 VR | 100 VR | 200 VR | 300 VR | 500 VR |
|---------------------------|------|-------|-------|--------|--------|--------|--------|
| Nominal Content –litres | 8 | 25 | 60 | 100 | 200 | 300 | 500 |
| D mm | 206 | 295 | 409 | 480 | 634 | 634 | 740 |
| D1 mm | - | 228 | - | - | - | - | - |
| H mm | 320 | 485 | 740 | 840 | 980 | 1280 | 1485 |
| Water Connection DN BSP | ¾" | 1" | 1" | 1" | 1 ¼" | 1 ¼" | 1 ¼" |
| Weight Kg | 2.4 | 5.6 | 25 | 32 | 50 | 55 | 85 |
| Max. working Pressure-bar | 10 | 10 | 10 | 10 | 10 | 10 | 10 |

All vessels must be securely mounted to prevent any movement from imposing strain on the attached pipework. Vessels of 60 litres capacity or greater **MUST** be mounted vertically on the integral legs with water connection lowermost.

Set up the vessel so the air charge filling valve (top) and the diaphragm (bottom) are accessible for future maintenance. All vessels must have isolating and drain off valves fitted to enable them to be serviced. The connecting pipework should be removable to give access for replacing the diaphragm and should be the same size as the vessel connection to minimise friction losses.

Set the air cushion pre-charge pressure to the correct level, dependent on the application required for the vessel. Refer to the Operating parameters at the back of this manual or contact Aquatech-Pressmain for advice.

1.3.6 ELECTRICAL

READ GENERAL SAFETY INFORMATION 0.0, WARNINGS 0.1 and CAUTIONS 0.2, 0.3 & 0.4

- 1.3.6.1 All wiring must comply with **IEE Regulations 16th Edition**.
- 1.3.6.2 **Wear anti-static wrist strap at all times** to avoid static discharge causing problems with the built in electronic program.
- 1.3.6.3 Connect incoming electrical mains supply to identified terminals on isolator IS1 in panel (see fig. 1.3). Ensure voltages and frequency indicated on the motor nameplates and wiring diagrams correspond with supply mains data and that the supply fuse ratings are correct for the total current rating of the equipment. Note: some units may require Neutral supply for special applications. Refer to wiring diagram supplied with the unit or contact AquaTech-Pressmain.
- 1.3.6.4 Where optional remote fault signal is required connect volt free terminals in control panel to remote panel. See fig 1.3 and wiring diagram provided.
- 1.3.6.5 Complete any required earth bonding.

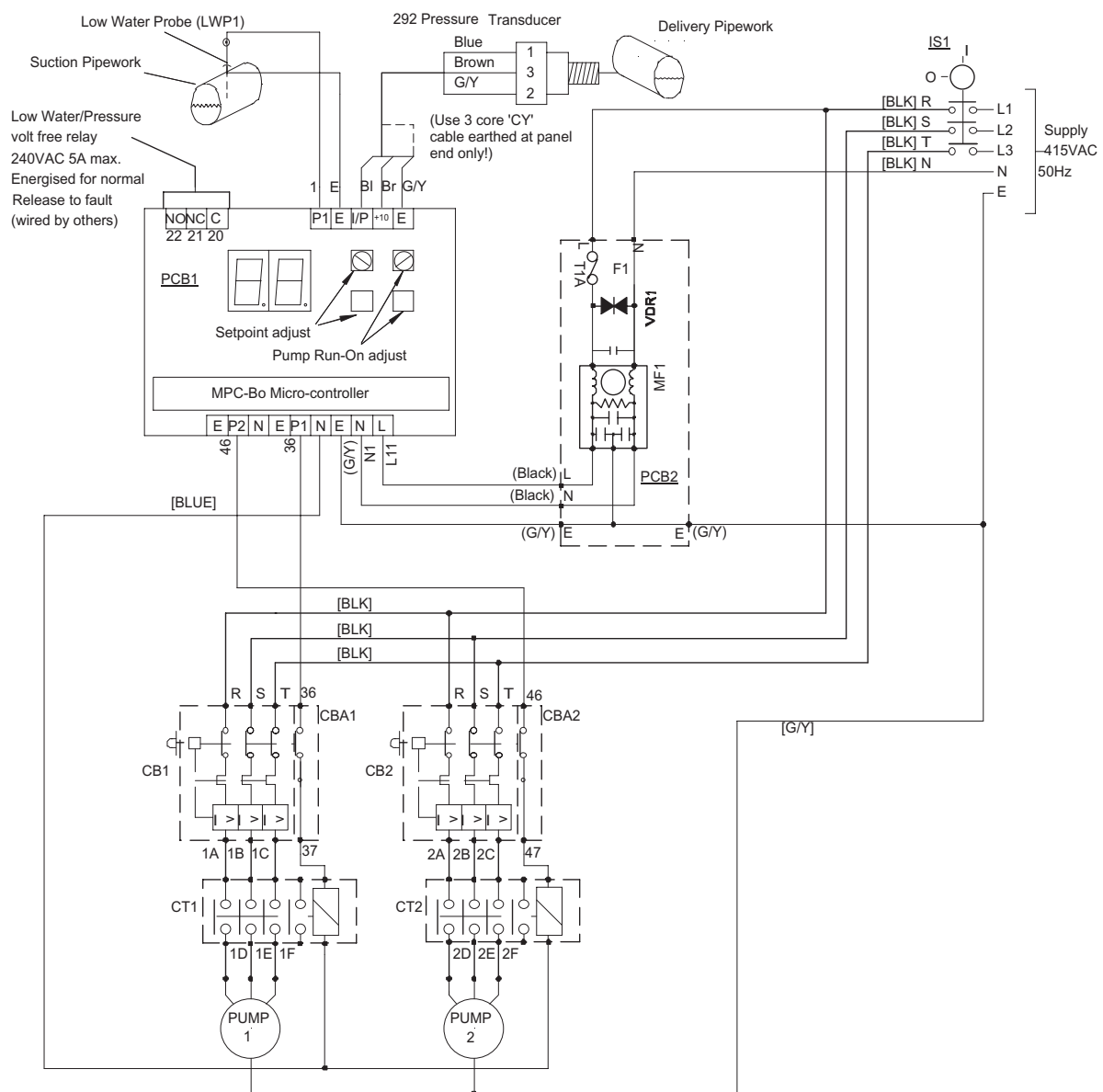

Fig. 1.3 Typical example of electrical connections

2. USER INSTRUCTIONS

2.1 CUSTOMER ASSURANCE

AQUATECH-PRESSMAIN ASSURE YOU THAT IF ANY PART OF THIS EQUIPMENT BECOMES DEFECTIVE DUE TO FAULTY MANUFACTURE OR MATERIALS WITHIN 12 MONTHS FROM THE DATE OF INVOICE OR 12 MONTHS FROM DATE OF COMMISSIONING BY AUTHORISED AQUATECH-PRESSMAIN AGENT, THE PART WILL BE REPAIRED OR REPLACED.

The only conditions are: -

- ◆ The equipment must have been installed, operated and maintained as recommended by **AquaTech-Pressmain Limited**.
- ◆ The equipment must not have been neglected, misused, modified, or used for any other purpose than its original application.
- ◆ The commissioning should be carried out within 6 months of the date of invoice by an authorised **AquaTech-Pressmain Limited** agent.
- ◆ This Assurance does not apply to those items not supplied by us or to defects arising from parts not made or approved by **AquaTech-Pressmain Limited**. The individual manufacturers own policies for dealing with defects will apply.
- ◆ Any part repaired or replaced under these Assurances will be covered for the balance of the appropriate Assurance period.
- ◆ If we have any disagreement about these Assurances which we are unable to resolve we will both abide by the decision of an agreed Arbitrator or, if we are unable to agree, one appointed by the Heating and Ventilating Contractors Association (HVCA) Arbitration Scheme Rules.
- ◆ These Assurances are in addition to, and do not detract from, the contractual rights you have under Statute or at common law.

For full details please see the AquaTech-Pressmain Ltd. "CONDITIONS OF SALE"

2.2 COMMISSIONING

Whilst this set has been tested in the factory to the required settings (detailed in operating parameters at the back of instruction manual), it is impossible to simulate the actual on-site conditions, especially if they are unusual. Also, the settings may have been disturbed since leaving the factory.

Therefore we strongly recommend **the set is commissioned by our authorised agent** who will prepare the set, make any necessary adjustments and leave the set in operational order.

Commissioning also enhances the Warranty (see Customer Assurance)

Prior to requesting an engineer to attend the site for commissioning, the client must ensure that;

- the equipment has been correctly installed;
- a written scheme of examination has been obtained where required under the Pressure Systems Safety Regulations
- any necessary chlorination or other treatment has been completed;
- an adequate water supply and permanent electricity supply are available;
- the pipework in the building being served by the pumpset is capable of accepting the generated pressures.

2.3 OPERATING INSTRUCTIONS FOR MICROMATIC PRESSURE BOOSTER SETS SERIES HM2ET

These pumpsets are used for increasing the supply pressure of cold potable water and other liquids.

READ GENERAL SAFETY INFORMATION 0.0, WARNINGS 0.1 and CAUTIONS 0.2, 0.3 & 0.4

2.3.1 ADDITIONAL CAUTIONS

2.3.1.1 READ GENERAL SAFETY INFORMATION 0.0, WARNINGS 0.1 and CAUTIONS 0.2, 0.3 & 0.4

2.3.2 NORMAL OPERATION

The Micromatic pressure booster set increases and maintains the supply pressure to a preset 'Duty' pressure.

The pumpset consists of two pumps mounted on a base frame together with associated suction and discharge pipework and valves linked in parallel with a hydraulic accumulator. The controls are in a set mounted panel.

When switched on the display shows the controller type

Bo

Then self checks stating the firmware ref.

05

Followed by the system pressure in bar

2.3

(Screens shown are examples only)

Pump Operation

Intermittent running duty pump with optional support pump meeting demand.

Duty Pump Rotation

To spread the wear evenly across the pumps the duty pump is automatically rotated each time all pumps stop.

Pressure setting

The pumpset is set at the required 'duty' pressure at the factory. If necessary, the pressure will be adjusted at commissioning to suit local conditions.

2.3.3 SYSTEM ALARMS

Flashing display giving type of fault, volt-free output signal, corrective action as described.
(see below)

| Displayed Message | Cause | Check |
|--|--|---|
| "LP" (Low pressure) | system pressure at/below low pressure setting & delay timer expired | Pressure vessel air charge wrong? Or water usage exceeds design capacity? Or pump(s) are tripped or air locked. |
| "LL" (Low water Level) | water level below supply tank low water alarm probe or pipework sensor dry. (240 second delay on automatic restart, after restoration of water level). | Break tank float valve stuck closed? Or output of pumpset exceeds mains water supply into break tank? Mains water interruption to break tank? |
| "rS" (pump Restart sequence initiated) | Once a Low Level condition has cleared, the unit displays "rS" and the current system pressure. The pumps will then perform their restart sequence for a set period of time, to clear any air present in the pumps | Check cause of Low water Level condition as above. |
| "Or" (system pressure Over Range) | Pressure sensor output above 9.9 Bar or pressure sensor not connected correctly. | Pressure higher than 9.9 Bar? Or pressure sensor failed? Or pressure sensor wiring loose? |
| "SP" (setpoint point out of range) | The setpoint pressure has been set either below 1.2 Bar or above 9.9 Bar. | Adjust setpoint pressure within normal range. |

Motor Overload fault Isolate the pumpset hydraulically, Switch off isolator, open control panel. Look for tripped motor circuit breaker MCB1, MCB2, etc investigate and rectify the cause of the trip, then turn the tripped MCB fully off and then fully on to reset the overload. Close panel door and switch on the isolator again. After the pumpset has completed its power up procedure SLOWLY open the discharge valve to allow the system to refill. WARNING; opening the discharge valve too quickly could cause hydraulic shock to occur and cause damage the system.

REMOTE SIGNAL

- Volt free single pole changeover contact in control panel (see fig 1.3) :

The Volt free relay is energised for normal operating conditions and drops out if there is: Low System Pressure or Low Water in suction pipe.

VENTING PUMPS

To vent pumps:

ISOLATE control panel and discharge valve

Undo air vent screw on each pump body until all the air is released (fig 2.1)

Re-tighten screws

Switch ON panel isolator

Slowly open discharge valve.

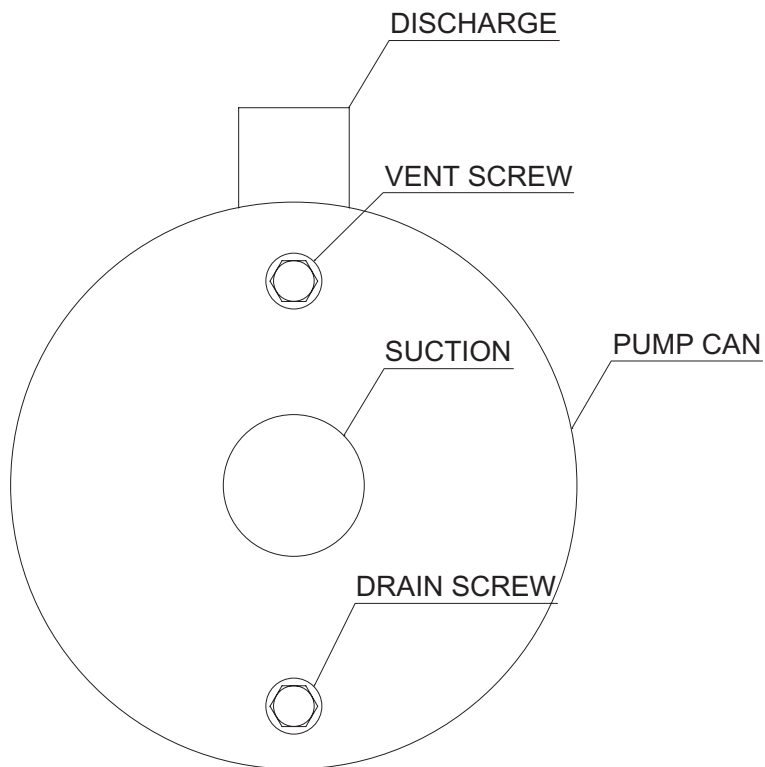

Fig 2.1 Venting Pumps

If a problem persists contact AQUATECH-PRESSMAIN LIMITED service department Quoting the serial number WN:_____ (on control panel fascia)

2.4 MAINTENANCE INSTRUCTIONS

FOR MICROMATIC PRESSURE BOOSTER SET SERIES HM2ET

2.4.1. ADDITIONAL CAUTIONS

2.4.1.1 READ GENERAL SAFETY INFORMATION 0.0, WARNINGS 0.1 and CAUTIONS 0.2, 0.3 & 0.4

2.4.2 PROCEDURE

All models: Every 6 months the pumpset should be maintained by authorised AquaTech-Pressmain service agents - see Servicing

Pump Lubrication

HORIZONTAL PUMPS WITH FLANGE-MOUNTED MOTORS require no lubrication as the impeller shafts are carried on the motor bearings.

Motor Lubrication

Motor bearings are normally sealed and require no lubrication. However should a motor have a grease point use good quality grease, and completely renew every two years.

Expansion, Control and Hydro Accumulator vessels

1. **Air Charge Pressure.** The correct charge pressure provides reliable operation of the system and a prolonged lifetime of the diaphragm. This should be checked regularly. To adjust: isolate the vessel from the system and release pressure on water side by opening the drain cock disposing of the water-mix in the appropriate manner. The water inside the bladder will be pushed back by the air charge pressure. Remove cap on the filling valve, set air charge pressure refilling using dry air or nitrogen. Screw cap firmly on filling valve. Close the drain cock and open water connection to the system.
2. **Replacement of the diaphragm** (except for 8 litre vessels where the complete vessel is replaced). Isolate vessel from the system and drain water from vessel using drain cock disposing of the water-mix in the appropriate manner. Release air charge. Remove water connection flange A. Release diaphragm support B by removing cap F and nut C on dished end D. Remove diaphragm E from inside the bottom opening.

Check vessel for dirt, corrosion etc., remove or flush with water. The diaphragms are not oil resistant and oily liquids must not be used to protect the inside surfaces of tanks against corrosion. The vessel should be dry when replacing diaphragm.

Put support B in new diaphragm and pass a flexible cord through the hole in support B, securing it on the underside. Roll up diaphragm in the longitudinal axis and pull the diaphragm by means of the cord into the vessel as far as the fixing opening in the top, then remove rope. Secure support B by fitting washer U and nut C. Fit cap F on top of B and close vessel by replacing flange A.

Recharge with dry air or nitrogen as above. Check vessel for leaks and reconnect to the system.

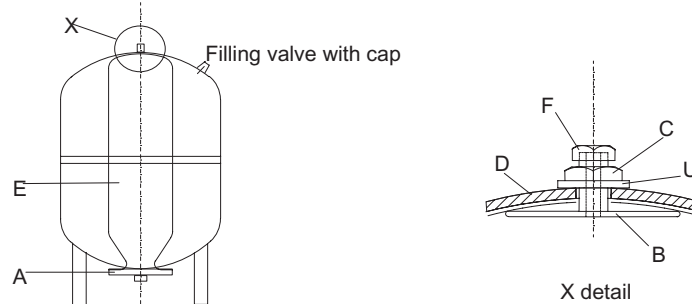

LEAVE SET WITH ALL PUMPS SWITCHED ON , AND THE MAINS SUPPLY SWITCHED ON.

3. SERVICING

3.1 MAINTENANCE AND CARE OF YOUR EQUIPMENT

The AquaTech-Pressmain equipment that is described in this instruction booklet has been manufactured and tested to the highest standards of design and quality. It will give trouble free operation over many years provided it is maintained regularly from when it is commissioned. To keep it operating efficiently in a safe, economical and environmentally friendly condition, regular maintenance is an essential part.

AquaTech-Pressmain Limited along with its' sister company, and fellow AGM Group member, Acorn Pressurisation Services Ltd are the official providers of commissioning and maintenance services. (see below).

Several companies operating under the Aquatronic Group Management structure are available to fulfil a wide range of servicing and maintenance requirements, as detailed below.

3.2 LEGAL REQUIREMENTS

Hydraulic Accumulators/Expansion Vessels installed as part of/in conjunction with this equipment, with Pressure x Volume above 250 Bar-litres, require formal inspection in accordance with a "Written Scheme of Examination". This is a Legal Requirement on the part of the Owner/User under the "Pressure Systems Safety Regulations" (PSSR). A "Written Scheme" and regular inspection can be provided by either Acorn Pressurisation Services (combined maintenance and inspection) or ESIS Ltd (inspection only), see details below.

Plant Servicing & Inspection



ACORN PRESSURISATION SERVICES LIMITED,
AGM House, Essex, CO6 1GT. Ph: 01206 215151
130 Princess Rd, Manchester, M16 7BY. 0161 226 4727

Acorn provides maintenance and installation of all types of packaged water pumping equipment for building services. Its specialist fields are Pressure booster equipment and sealed systems for heating and chilled water distribution systems.

Regular servicing of any plant for essential services is vital because wear and tear are very gradual processes. With preventative maintenance, the costs are small and benefits in reliability, safety and economy can be significant. Acorn Pressurisation Services Ltd can provide a complete package of schemes for preventative maintenance on all AquaTech-Pressmain and other makes of equipment.

Pressure Vessel Inspection



ESIS ENGINEERING SAFETY & INSPECTION SERVICES LTD,
AGM House, London Rd, Copford, Colchester, Essex, CO6 1GT.
Phone: 01206 215141 Fax: 01206 215142

Under the Pressure Systems Safety Regulations, expansion vessels and hydraulic accumulators, generally 250 bar-litres and greater, and protection devices, require a Written Scheme of Examination before they can be operated. ESIS Inspection and Insurance Services Limited specifications can provide the means to comply with these regulations. These services can be extended to cover other units e.g. air pressure receivers etc.

3.3 SERVICE CONTACTS

For service during warranty period contact: AQUATECH-PRESSMAIN Service Department

Head Office Tel: 01206 215121

Manchester Office Tel: 0161 226 4727

For regular servicing, contact their service agents: ACORN PRESSURISATION SERVICES LTD

Head Office Tel: 01206 215151

Manchester Office Tel: 0161 226 4727

who will be pleased to give you expert advice on this or any other servicing matter.

Notes:

4. DISPOSAL

Disposal of this product or parts of it must be carried out in accordance with the following guidelines:

- 4.1 Use the local public or private recycling/waste collection service.
- 4.2 In case such a recycling/waste collection service does not exist or cannot handle the materials used in this product, please deliver the product or any hazardous material from it to your nearest AquaTech-Pressmain office.

EC Declaration of Conformity

We, AquaTech-Pressmain Limited, declare this Pressure Equipment Assembly:

**PRESSURE BOOSTER SET
MODEL: Micromatic HM2**

Complies with the following standards:

**BS EN 60204-1:2006
EN61000-6-3:2001, EN61000-6-1:2001**

and meets the requirements of EEC Directives:

**Pressure Equipment Directive 97/23/EC (PED)
Low Voltage Directive 73/23/EEC and 93/68/EEC
Electro Magnetic Compatability Directive 89/336/EEC with
amendments 92/31/EEC.**

**PED Conformity Assessment Modules : B + D
Notified Body : BSI Product Services,
Maylands Avenue
Hemel Hempstead
Hertfordshire
HP2 4SQ**

Type Examination Certificate Ref. CE95657



30.07.2005

I.D.Taylor, I.Eng, MIET, Director, AquaTech-Pressmain Limited.

AquaTech-Pressmain Limited
AGM House, London Rd, Copford, Colchester, Essex CO6 1GT UK
Telephone: 01206 215121 Fax: 01206 215131

OPERATING PARAMETERS

SERIAL No. **MODEL**.....

THE SERIAL & MODEL NUMBERS MUST BE QUOTED WHEN REQUESTING ASSISTANCE

ELECTRICAL DATA:

Supply volts Ph Hz

Full load current of pumpset Amps

Max. pumpset loading: Kw Method of starting: DOL

NOISE LEVEL: less than 70 db(A) unless otherwise stated

NOMINAL FLOW RATE: litres/sec

PRESSURE SETTINGS:

AS FACTORY SET

bar mins

Pump Duty pressure

Hyd. Accumulator:

Pump closed valve press.

Low pressure

Minimum run time

| ❖ AMENDED AT COMMISSIONING | |
|----------------------------|-------|
| bar | mins |
| | |
| | |
| | |
| | |

❖ On commissioning it may be found necessary to modify these settings. Providing this information is left with the equipment, the figures will be updated by the commissioning engineer.

Updated by commissioning engineer **Date**