



AquaTech Pressmain

INSTRUCTIONS FOR

0. GENERAL SAFETY INFORMATION, WARNINGS & CAUTIONS
1. INSTALLATION
2. THE USER
3. SERVICING
4. DISPOSAL

MM-AT-E-15 COLD WATER PRESSURE BOOSTER SET

MODEL: MM-AT-E-15









CE

ISSUE: 4 18/03/10

Head Office: AGM House, London Rd, Copford, Colchester, Essex CO6 1GT UK
Tel: 01206 215121 Fax: 01206 215131

Manchester Office: Dolphin House, 130 Princess Road, Manchester M16 7BY
Tel: 0161 226 4727 Fax: 0161 226 5848

CONTENTS

		0.0 GENERAL SAFETY INFORMATION		3
0.1		WARNINGS		3
0.2		CAUTIONS FOR INSTALLATION		4
0.3		CAUTIONS FOR OPERATION/USER		5
0.4		CAUTIONS FOR MAINTENANCE		6
1.		INSTALLATION INSTRUCTIONS		7
1.1		GENERAL		7
1.2		ADDITIONAL WARNINGS & CAUTIONS		7
1.3		PROCEDURE		7
1.3.1		OFF-LOADING AT SITE		7
1.3.2		LOCATION		7
1.3.3		FIXING		7
1.3.4		ELECTRICAL		8
2.		USER INSTRUCTIONS		9
2.1		CUSTOMER ASSURANCE		9
2.2		COMMISSIONING		9
2.3		OPERATING INSTRUCTIONS		10
2.3.1		ADDITIONAL WARNINGS & CAUTIONS		10
2.3.2		NORMAL OPERATION		10
2.3.3		POSSIBLE PROBLEMS		11
3.		SERVICING		11
3.1		MAINTENANCE AND CARE OF YOUR EQUIPMENT		11
3.2		LEGAL REQUIREMENTS		11
3.3		SERVICE CONTACTS		11
4.		DISPOSAL		12
		OPERATING PARAMETERS		12

0.0 GENERAL SAFETY INFORMATION

- These instructions are intended for the installer/operator/user/maintenance of this equipment and must be kept with the equipment, for the life of the equipment and made available to all persons. Please read GENERAL SAFETY INFORMATION 0.0, WARNINGS 0.1 and CAUTIONS 0.2, 0.3 & 0.4 before doing anything else, and then follow them carefully.
- The unit must only be installed/operated/used/maintained by a competent person; *A competent person is someone who is technically competent and familiar with safety practices and the hazards involved.*
- Hydraulic Accumulators/Expansion Vessels installed as part of/in conjunction with this equipment, with Pressure x Volume above 250 Bar-litres, require regular formal inspection by a *competent person*. This is a Legal Requirement under the “Pressure Systems Safety Regulations” (PSSR) and the Owner/User should be made aware of their responsibility for this. (see section 3. Servicing).
- Failure to install/operate/use/maintain the equipment as recommended below could cause damage to the equipment any anything subsequently connected to it, and invalidate the warranty provided by AquaTech-Pressmain to the buyer.
- Any damage caused to the equipment by misapplication, mishandling or misuse could lead to risk of **Electrocution, Burns, Fire, Flooding or injury to people or property** dependent upon the circumstances involved.
- This equipment contains moving/rotating parts that must remain guarded. Removal of or missing guards could lead to serious personal injury.
- This equipment automatically restarts after a power interruption.
- We accept no responsibility or liability for any consequences or damage/losses due to misapplication, mishandling or misuse of the equipment.
- It should be noted that the assembly of pressure equipment on site under the responsibility of the user (or his representative) is not subject to the Pressure Equipment Directive 97/23/EC. (National legislation covering assembly on site will apply)
- The latest version of this instruction manual with up to date safety information can be downloaded from our website at www.aquatechpressmain.co.uk

0.1 WARNINGS

- 0.1.1 **Do not touch any live parts for at least 5 minutes after switching off the electricity supply. Failure to observe this will constitute a severe Electric shock and/or Burns hazard and may be lethal.**
- 0.1.2 **The equipment is only suitable for earth referenced supplies and must be permanently earthed to avoid Electric shock hazard.**
- 0.1.3 **With equipment isolator OFF, mains voltage may still be present from BMS system. This constitutes an Electric shock hazard.**
- 0.1.4 **Emergency stop button does not remove dangerous voltages from control panel/pump motor assemblies. This constitutes an Electric shock hazard.**
- 0.1.5 **Metal parts (e.g. heat sinks) may reach temperatures of 90 degrees centigrade and will constitute a Burns hazard.**
- 0.1.6 **Some equipment is designed to operate with liquid temperatures up to 150 degrees centigrade and will constitute a Burns/scalding hazard.**
- 0.1.7 **The equipment must not be pressurised beyond the maximum working pressure as stated on pumps/pipework/vessels/control panel otherwise serious mechanical damage/destruction could occur causing injury to people or property.**
- 0.1.8 **The equipment must not be heated/chilled beyond the maximum/minimum working temperature as stated on pumps/pipework/vessels/control panel otherwise serious mechanical damage/destruction could occur causing injury to people or property.**

- 0.1.9 Any damage to equipment, pumpset, vessels, pipework or system components caused by misapplication, mishandling or misuse could lead to Electric shock hazard, Burns hazard, Fire hazard, Flooding hazard or cause injury to people or property.
- 0.1.10 This equipment may contain moving/rotating parts that must remain guarded. Removal of or missing guards could lead to serious personal injury.
- 0.1.11 Pressure vessels must never be disassembled whilst in use, they contain high pressure air/gas charge which could cause injury to people or property.
- 0.1.12 Pump motors with lifting eyes; the lifting eyes are only suitable for lifting motors NOT the entire pump assembly. This could cause injury to people or property.
- 0.1.13 Ensure the base/foundation/plinth/wall to which the equipment is to be attached is sufficiently strong enough to carry the entire mass of the equipment including the water that it will contain under worst-case fault conditions. E.g. fully saturated pressure vessel with no air charge, break tank full to overflowing, etc. Failure to observe this could cause serious mechanical damage/destruction resulting in injury to people or property.



0.2 CAUTIONS FOR INSTALLATION

- 0.2.1 READ GENERAL SAFETY INFORMATION 0.0, WARNINGS 0.1 and CAUTIONS 0.2, 0.3 & 0.4
- 0.2.2 The unit should only be installed/operated by a competent person; *A competent person is someone who is technically competent and familiar with safety practices and the hazards involved.*
- 0.2.3 Do not lift the pumpset by pipework. Lift the pumpset by the container pallet using a pallet/forklift or crane by passing strops underneath the skid using a spreader bar. Failure to utilise these facilities will result in damage to the pumpset.
- 0.2.4 Store in a dry place to avoid damp conditions deteriorating the equipment.
- 0.2.5 Protect against dirt, damage and frost. It is absolutely essential that no foreign matter such as pipe thread swarf, welding slag, grit or stones are allowed to enter the set. Debris of this type can cause severe damage to the mechanical seals, diaphragms and impeller. Frost/freezing will damage pumps/pipework and control panel components.
- 0.2.6 The equipment is only suitable for installation in a clean, dust free indoor environment, with adequate protection from heat and frost, and sufficient ventilation to ensure cooling of the motors. Ambient air temperature should be between 5 and 40 degrees centigrade, non-condensating. Operation outside of these conditions could seriously damage the equipment.
- 0.2.7 If the equipment were to be stored or taken out of service for a period of time (e.g. 1 week or more), then we would recommend draining the equipment of all water/liquid (with due regard to any local regulations) to prevent frost damage to components. When restarting is required we would recommend commissioning by our authorised service agent.
- 0.2.8 Ensure the base/foundation/plinth/wall to which the equipment is to be attached has sufficient mass compared to the equipment, in order to avoid noise/vibration transmission. E.g. the mass of the base should be at least five times the mass of the equipment.
- 0.2.9 Ensure the electrical supply is the correct voltage, current, frequency and type for the equipment supplied and that suitable circuit protection equipment is installed in the supply. Incorrect electrical installation could be an electric shock/burns/fire hazard.
- 0.2.10 When accessing the control panel to make electrical connections adopt anti-static procedures e.g. wear anti-static earthed wristband, to avoid risk of damaging the controller.
- 0.2.11 All products that are packaged to include Pressure vessel(s)/Hydraulic Accumulator(s)/Expansion Vessel(s) are classed as "Assemblies" under the Pressure Equipment Directive (PED). Where units are despatched with "Loose" vessel(s) for assembly on site it is absolutely essential that they be installed as detailed in the instructions using the fittings provided where appropriate. Failure to observe this will nullify compliance with the PED and may present a safety hazard. Your warranty may also be affected.
- 0.2.12 Where Hydraulic Accumulator(s)/Expansion Vessel(s) are supplied as a loose item, they must be installed/connected correctly before operating the equipment, otherwise serious damage from over-pressure/pump overheating could occur.
- 0.2.13 Do not operate this equipment/pumpset prior to commissioning (section 2.2) This could cause irreparable damage to equipment/pumpset/pipework/system components.

- 0.2.14 Isolate the equipment/pumpset before pressure testing system. Excess pressure could irreparably damage the pressure transducer, pressure switches (where fitted) and the diaphragms of pressure vessel/hydraulic accumulators.
- 0.2.15 It is the installers' responsibility to ensure subsequent pipework etc can accept the pressures generated by the equipment/pumpset and to install an overpressure safety device into the system with due respect to the suction pressure present on the pumpset, the pump closed valve pressure stated on the pump, the maximum working pressure stated on any of the attached pressure vessels and any other device connected to the system e.g. boilers, calorifiers etc.
- 0.2.16 When chlorination of the system is carried out, ensure that any residual chlorine is removed by thorough flushing as detailed in the HSE approved code of practice L8, to avoid damaging the equipment/pumpset. The normal level of chlorination is up to 2 parts per million (ppm), but shock dosing for sterilization purposes, at 25-50 ppm for 24-48 hours is acceptable as long as all chlorine is removed once the process is complete. Chlorination beyond these limits could seriously damage pumpset components and WILL NOT be covered by the warranty.
- 0.2.17 The installer/user is responsible for the installation of the correct earthing and protection according to valid national and local standards. All operations must be carried out by a suitably qualified person.
- 0.2.18 The equipment is only suitable for earth referenced supplies and must be permanently earthed to avoid electric shock hazard.
- 0.2.19 The equipment must be permanently earthed with appropriate sized Earthing.
- 0.2.20 Never perform high voltage resistance tests on control panels, variable speed drives/motors without first disconnecting the panel/drive/motor from the circuit being tested as this will damage the built in electronic components.
- 0.2.21 Metal parts (e.g. heat sinks) may reach temperatures of 90 degrees centigrade.
- 0.2.22 EMC - With respect to BS EN61000-3-2 this equipment is defined as 'professional equipment' and therefore the installer/user may need to seek permission from the supply utility to connect this equipment to the public low voltage mains supply.
- 0.2.23 Where "Expansion vessels" are used on Domestic hot water systems (DHWS) or LTHW heating system pressurisation units, the temperature of the fluid returning to the vessels should not exceed 70 degrees Centigrade as this could damage the vessel diaphragm. Where the temperature exceeds 70C an intermediate cooling vessel should be fitted.
- 0.2.24 Drain cocks/valves and air bleed screws must not be left open as this could cause flooding.



0.3 CAUTIONS FOR OPERATION/USER

- 0.3.1 READ GENERAL SAFETY INFORMATION 0.0, WARNINGS 0.1 and CAUTIONS 0.2, 0.3 & 0.4
- 0.3.2 The unit should only be operated/used by a competent person; *A competent person is someone who is technically competent and familiar with safety practices and the hazards involved.*
- 0.3.3 The Owner/User of this equipment has a Legal Responsibility to ensure that it is subject to regular formal inspections. See Section 3. Servicing, for details.
- 0.3.4 Where Hydraulic Accumulator(s)/Expansion Vessel(s) are supplied as a loose item, they must be installed/connected correctly before operating the equipment, otherwise serious damage from over-pressure could occur.
- 0.3.5 The set must not be run until commissioned by an authorised AquaTech-Pressmain agent, this could irreparably damage the pump set and/or system components/pipework connected to it.
- 0.3.6 The pumpset should be left switched ON with the pumps switched to AUTO for normal operation.
- 0.3.7 The pumpset should not be left in "Hand" operation for more than 1 minute. This could lead to severe damage of pumpset components and/or pipework system from over-pressure and/or overheating.
- 0.3.8 Ensure pumpset has an adequate water supply at all times to prevent dry running causing pump seal damage and water leakage.
- 0.3.9 Do no attempt to start pumps without liquid in volutes (pumps must be fully primed); mechanical seals must have a film of liquid between faces for proper operation and to prevent damage.
- 0.3.10 Portable telephones or other electro-magnetic equipment must not be used near the set to avoid corruption of program and unpredictable operation of unit.



0.4 CAUTIONS FOR MAINTENANCE

- 0.4.1 READ GENERAL SAFETY INFORMATION 0.0, WARNINGS 0.1 and CAUTIONS 0.2, 0.3 & 0.4
- 0.4.2 The unit should only be operated/maintained by a competent person; *A competent person is someone who is technically competent and familiar with safety practices and the hazards involved.*
- 0.4.3 Where the set is fitted with Building Management Services (BMS) interconnections, notify the appropriate persons before switching OFF for maintenance or adjustments, to avoid unnecessary alarm conditions occurring. **WARNING:** With pumpset isolator OFF, mains voltage may still be present from BMS system. This constitutes an Electric shock hazard.
- 0.4.4 To prevent seizing, pumpsets must not be left unused for long periods (e.g. 1 week).
- 0.4.5 The pumps must be run regularly to avoid stagnation of water in the pumps/pipework (e.g. daily).
- 0.4.6 Do not vent air from air valves on vessels. These are for adjustment of pre-set cushion pressures. If wrongly adjusted this will lead to incorrect operation of the pumpset and possible damage to pumps, pipework and system components from overheating and over-pressure.
- 0.4.7 Switch OFF pumpset before accessing pumps and/or control panel.

1. INSTALLATION INSTRUCTIONS FOR PRESSURE BOOSTER SERIES: MM-AT-E

1.1 GENERAL

These instructions are intended for the installer of this pressure booster set. Please follow them carefully.

The unit should only be installed by a competent person. *A competent person is someone who is technically competent and familiar with safety practices and the hazards involved.*

It should be noted that the assembly of pressure equipment on site under the responsibility of the user (or his representative) is not subject to the Pressure Equipment Directive 97/23/EC. (National legislation covering assembly on site will apply)

Failure to install the equipment as recommended below could invalidate the warranty provided by AquaTech Pressmain to the buyer.

1.2 ADDITIONAL WARNINGS & CAUTIONS

1.2.1 READ GENERAL SAFETY INFORMATION 0.0, WARNINGS 0.1 and CAUTIONS 0.2, 0.3 & 0.4

1.3 PROCEDURE

1.3.1 OFF-LOADING AT SITE

Do not lift pumpset by pipework. Lift the pumpset by the container pallet using a pallet/forklift or crane by passing strops underneath the skid using spreader bar. Failure to utilise these facilities could result in damage.

1.3.2 LOCATION

If the set is to be installed in an unheated room, ensure that there is adequate frost protection

Ensure that location for pumpset provides adequate clear space to accommodate unit with reasonable access to all parts; AquaTech Pressmain recommend a minimum distance of 500mm all round. There must be sufficient room to:-

- access all wiring;
- lift and withdraw pumps;
- withdraw diaphragms from vessels.
- remove pipework from pumps.

If necessary provide overhead lifting eyes for possible future use.

Any Hydraulic Accumulator supplied should be located as near as possible to the discharge side of the pumpset.

Should any of these location conditions not be satisfied AquaTech Pressmain reserve the right to charge labour on any warranty work required on the pumpset.

1.3.3 FIXING

- 1.3.3.1 Install the set on a flat, even and level surface, where practical on a raised plinth to keep set above damp floor.
- 1.3.3.2 Locate unit in position; fit anti-vibration mounts if supplied. If necessary level the base by inserting packing strips adjacent to bolt positions. Firmly attach pumpset to base.
- 1.3.3.3 Protect against frost. An insulation jacket is provided for the tank.
- 1.3.3.4 Do NOT fit a non-return valve to the outlet (system connection).
- 1.3.3.5 Wall Mounting: A wall-mounting bracket is available as an optional extra on request. See Fig 1.1 for assembly.
- 1.3.3.6 Mains water supply: Connect to 15mm inlet valve in tank. Ensure minimum of 1 Bar pressure. Fill the tank. Ensure flow rate into tank equals or exceeds flow rate out of tank/pump. See Fig 2.1
- 1.3.3.7 If necessary adjust the float to cut off supply just below the warning pipe.
- 1.3.3.8 Outlet: Fit isolating valve to 1" system connection and hose/pipe as required.

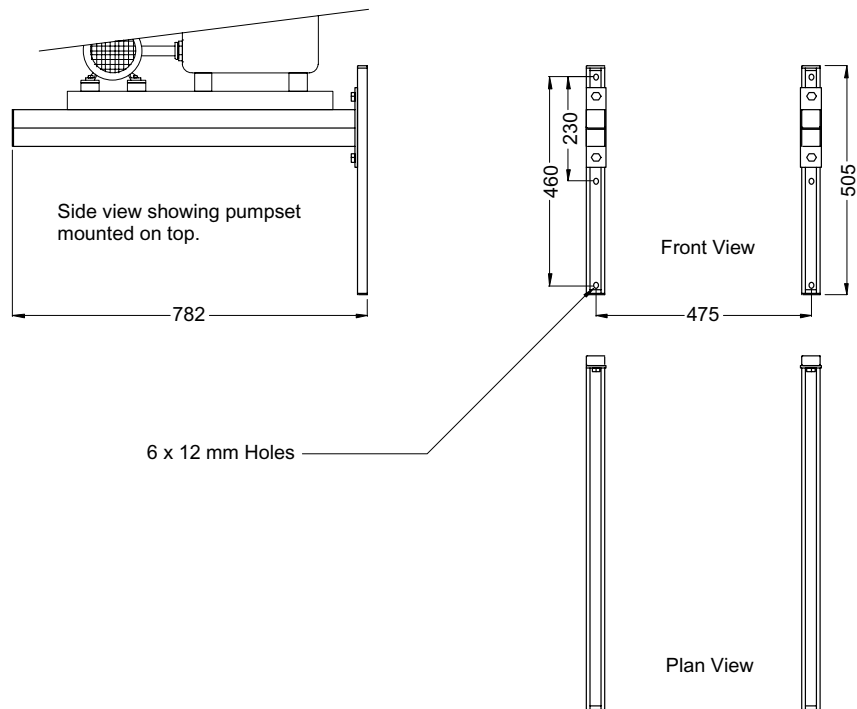

Fig 1.1 Optional extra Wall mounting bracket assembly: -Fix each arm to an upright: place 2 grip nuts in upright channel, turn nut through 90°, then bolt arm in place. Fix uprights to wall using the 6 x 12 mm holes.

1.3.4 ELECTRICAL

READ GENERAL SAFETY INFORMATION 0.0, WARNINGS 0.1 and CAUTIONS 0.2, 0.3 & 0.4

1.3.4.1 All wiring must comply with the latest edition of local wiring regulations.

1.3.4.2 Connect incoming switch fused electrical mains supply to identified terminals in the Presscomfort controller (see fig. 1.2). Ensure voltages and frequency indicated on the motor nameplates and wiring diagrams correspond with supply mains data and that the supply fuse ratings are correct for the total current rating of the equipment Refer to wiring diagram supplied with the unit or contact AquaTech Pressmain.

1.3.4.3 Complete any required earth bonding.

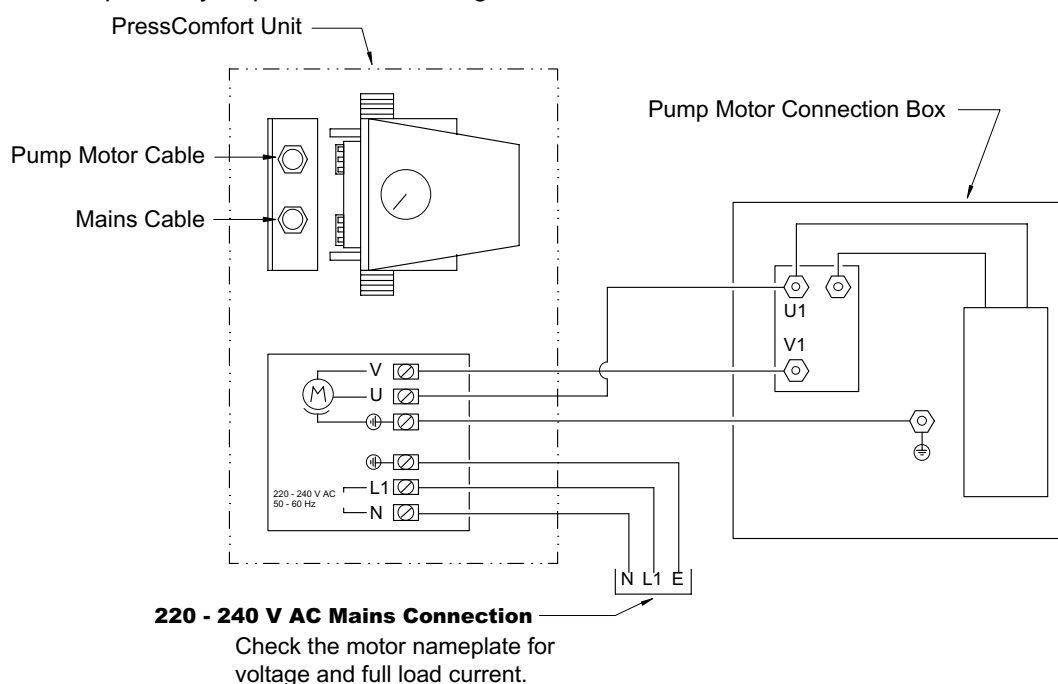

Fig 1.2

2. USER INSTRUCTIONS

2.1 CUSTOMER ASSURANCE

AQUATECH PRESSMAIN ASSURE YOU THAT IF ANY PART OF THIS EQUIPMENT BECOMES DEFECTIVE DUE TO FAULTY MANUFACTURE OR MATERIALS WITHIN 12 MONTHS FROM THE DATE OF INVOICE OR 12 MONTHS FROM DATE OF COMMISSIONING BY AUTHORISED AQUATECH PRESSMAIN AGENT, THE PART WILL BE REPAIRED OR REPLACED.

The only conditions are: -

- ◆ The equipment must have been installed, operated and maintained as recommended by **AquaTech Pressmain**.
- ◆ The equipment must not have been neglected, misused, modified, or used for any other purpose than its original application.
- ◆ The commissioning should be carried out within 6 months of the date of invoice by an authorised **AquaTech Pressmain** agent
- ◆ This Assurance does not apply to those items not supplied by us or to defects arising from parts not made or approved by **AquaTech Pressmain**. The individual manufacturer's own policies for dealing with defects will apply.
- ◆ Any part repaired or replaced under these Assurances will be covered for the balance of the appropriate Assurance period.
- ◆ If we have any disagreement about these Assurances which we are unable to resolve we will both abide by the decision of an agreed Arbitrator or, if we are unable to agree, one appointed by the Heating and Ventilating Contractors Association (HVCA) Arbitration Scheme Rules.
- ◆ These Assurances are in addition to, and do not detract from, the contractual rights you have under Statute or at common law.

For full details please see the AquaTech Pressmain "CONDITIONS OF SALE"

2.2 COMMISSIONING

Whilst this set has been tested in the factory to the required settings (detailed in operating parameters at the back of instruction manual), it is impossible to simulate the actual on-site conditions, especially if they are unusual. Also, the settings may have been disturbed since leaving the factory.

Therefore we strongly recommend **the set is commissioned by our authorised agent** who will prepare the set, make any necessary adjustments and leave the set in operational order.

Commissioning also enhances the Warranty (see Customer Assurance)

Prior to requesting an engineer to attend the site for commissioning, the client must ensure that;

- the equipment has been correctly installed;
- a written scheme of examination has been obtained where required under the Pressure Systems Safety Regulations
- any necessary chlorination or other treatment has been completed;
- an adequate water supply and permanent electricity supply are available;
- the pipework in the building being served by the pumpset is capable of accepting the generated pressures.

2.3 OPERATING INSTRUCTIONS FOR PRESSURE BOOSTER SERIES MM-AT-E

These pumpsets are used for increasing the supply pressure of cold potable water and other liquids.

General Description

In order to comply with Water Supply (Water Fittings) Regulations 1999 for backflow prevention this pumpset incorporates a 15 gallon insulated breaktank with a type AB air gap suitable for all categories of water for supplying hoses and low pressure equipment.

The pump is controlled by the pressure at the outlet (system connection). The controller automatically starts or stops the pump as taps/valves are opened or closed.

2.3.1 ADDITIONAL WARNINGS & CAUTIONS

2.3.1.1 READ GENERAL SAFETY INFORMATION 0.0, WARNINGS 0.1 and CAUTIONS 0.2, 0.3 & 0.4

2.3.2 NORMAL OPERATION

2.3.2.1 Fill the tank. This will prime the pump.

2.3.2.2 Turn on the electrical supply. The pump will start after 20~25 seconds and run for a short while to pressurise the system.

2.3.2.3 On opening the outlet valve (flow>0.7l/min) the pump will start and run until the valve is closed (flow<0.7l/min).

2.3.2.4 If the static height of the system is more than 12 metres (1.2 Bar) then the starting pressure will need to be adjusted up to a maximum static height of 21 metres (2.1 Bar). The starting pressure can be adjusted by the screw in the side of the controller. The starting pressure must be 0.2 Bar higher than the static height pressure and the pump must produce at least 0.5 Bar above the starting pressure in order for the pump to switch off.

2.3.2.5 If the tank runs out of water the Presscomfort controller will switch off the pump and the failure light will come on. Refill the tank then push the RESET button on the controller.

2.3.2.6 These units are covered by a 1 year parts only, return to base, warranty.

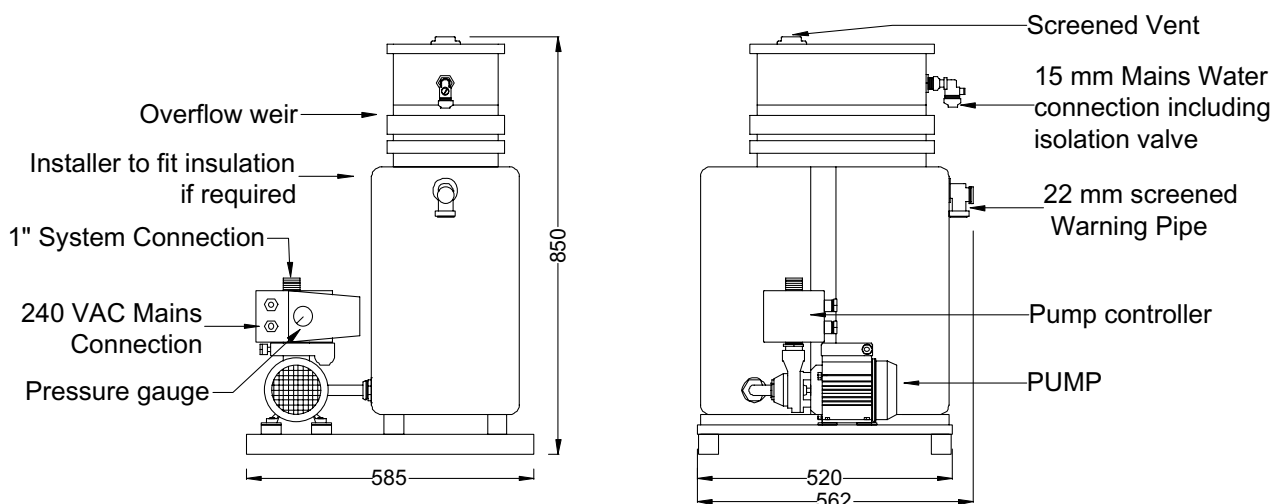

Fig 2.1

2.3.3 POSSIBLE PROBLEMS

Possible problem	Cause	Check
Pump does not stop	Water leak higher than 0.7l/min	Check installation for leaking taps etc.
	Reset switch not working	Press several times or call for assistance.
	Controller failed	Replace controller
	Incorrect electrical connections	Verify connections are correct
	Pump start pressure set too high	Adjust pump start pressure within range (e.g. 1.4 to 2.3 Bar)
Pump does not stop and Failure LED illuminated.	Not enough water supply	Check water supply and press "Reset" button
	Pump is blocked	Switch off power, Unblock pump, press "Reset" button
	Controller failure	Switch off power, wait 10 seconds, switch power on again.
	Pump airlocked	Vent pump
Not enough pressure and Failure LED illuminated	Controller setup incorrect	Rectify and restart
	Air in pump	Check for leaks, rectify and restart.

3. SERVICING

3.1 MAINTENANCE AND CARE OF YOUR EQUIPMENT

The AquaTech-Pressmain equipment that is described in this instruction booklet has been manufactured and tested to the highest standards of design and quality. It will give trouble free operation over many years provided it is maintained regularly from when it is commissioned. To keep it operating efficiently in a safe, economical and environmentally friendly condition, regular maintenance is an essential part.

AquaTech-Pressmain Limited along with its' sister company, and fellow AGM Group member, Acorn Pressurisation Services Ltd are the official providers of commissioning and maintenance services. (see below).

Several companies operating under the Aquatronic Group Management structure are available to fulfil a wide range of servicing and maintenance requirements.

3.2 LEGAL REQUIREMENTS

Hydraulic Accumulators/Expansion Vessels installed as part of/in conjunction with this equipment, with Pressure x Volume above 250 Bar-litres, require formal inspection in accordance with a "Written Scheme of Examination". This is a Legal Requirement on the part of the Owner/User under the "Pressure Systems Safety Regulations" (PSSR). A "Written Scheme" and regular inspection can be provided by either Acorn Pressurisation Services (combined maintenance and inspection) or ESIS Ltd (inspection only), phone 01206 215141.

3.3 SERVICE CONTACTS

For service during warranty period contact: AQUATECH-PRESSMAIN Service Department
Head Office Tel: 01206 215121 Manchester Office Tel: 0161 226 4727

For regular servicing, contact their service agents: ACORN PRESSURISATION SERVICES LTD
Head Office Tel: 01206 215151 Manchester Office Tel: 0161 226 4727

who will be pleased to give you expert advice on this or any other servicing matter.

4. DISPOSAL

Disposal of this product or parts of it must be carried out in accordance with the following guidelines:

- 4.1 Use the local public or private recycling/waste collection service.
- 4.2 In case such a recycling/waste collection service does not exist or cannot handle the materials used in this product, please deliver the product or any hazardous material from it to your nearest AquaTech-Pressmain office.

EC DECLARATION OF CONFORMITY
 We, Aquatech-Pressmain Limited, declare that this BOOSTER SET MODEL: MM-AT-E-15 when installed and used in accordance with the instructions provided is in conformity with the following standards: BS EN 60204-1: 2006, EN61000-6-3, EN61000-6-1 following the provisions of EEC Directives: Low Voltage Directive 73/23/EEC and 93/68/EEC; Electromagnetic Compatibility Directive 89/336/EEC with amendments 92/31/EEC.



I.D.Taylor, I.Eng.MIET, Director, Aquatech-Pressmain Limited. 16.04.02

OPERATING PARAMETERS

SERIAL No. **MODEL**.....

THE SERIAL & MODEL NUMBERS MUST BE QUOTED WHEN REQUESTING ASSISTANCE

ELECTRICAL DATA:

Supply **240** volts **1** Ph **50** Hz

Full Load Current of Pumpset **2.3** Amps

Max. pumpset loading: **0.37** Kw Method of starting: Direct on Line

NOISE LEVEL: less than 70 db(A) unless otherwise stated

NOMINAL FLOW RATE: **0.5** litres/sec

PRESSURE SETTINGS:

AS FACTORY SET

Pump Duty starting pressure **1.4~2.3** bar (for static height 12~21m above discharge)

Hyd.Accumulator:

Pump closed valve press. **2.8**

AMENDED AT COMMISSIONING	
bar	
.....	
.....	
.....	

❖ On commissioning it may be found necessary to modify these settings. Providing this information is left with the equipment, the figures will be updated by the commissioning engineer.

Updated by commissioning engineer Date