



AquaTech Pressmain

HEATING & CHILLED SYSTEM PRESSURISATION UNITS



'SA10-P' SERIES

GENERAL

The SA10-P range of units are suitable for low temperature hot water, chilled water and heat recovery systems with temperature ranges up to 90°C and a maximum pressure of 7 Bar.

The equipment comes fully packaged with single or twin pump, pipework, pressure controls, pressure gauge, pump NRV, and system valves, expansion vessel, with replacement diaphragm and all relevant electrical controls

Twin pump units also feature automatic changeover to cycle pumps one to the other.

- The design of the equipment allows for ease of servicing and component replacement as necessary.
- All units comply with M & E 3 specification and the water supply (water fittings) regulations 1999.

Pressure is maintained on the system by the pump/s controlled from pressure switch/es (or pressure transducer in the microprocessor version) controlling the pump operation.

On system contraction or loss of water from the system will bring the duty pump into operation alternatively, with an increase in pressure due to expansion, the water from the system is initially taken up in the nitrogen charged diaphragm pressure vessel, after which a solenoid valve operates to discharge water into the spill tank. There are six standard spill tank sizes in the range, and selection is determined by the total water content, temperature, and static head conditions of the system.

AquaTech Pressmain manufacture a complete range of pressurisation equipment. If in doubt please call one of our regional offices for advice in sizing the correct type of equipment for your installation. Details required:

Operating temperatures, flow and return.

Water content if possible (we can size approximately on the boiler rating)

Static height (highest point of heating system from the unit)

Boiler rating and number of boilers. Maximum working pressure. Electrical supply

Additions to the standard equipment include trip lamps, low water alarms, visual and audible alarms for high low pressure, hours run meters, remote indications for energy management systems.

-
- Maximum static height for standard unit – 20 meters
 - Cold fill pressure from – 1.0 bar
 - Suitable for boiler rating up to – 1MW
 - Single or Twin pumps
 - Pressure switch control
 - Suitable for temperatures up to 90°C
 - High and low pressure alarm with boiler/chiller interlock

The Aquatech Pressmain SA10-P series of heating and chilled water pressurisation units are fully packaged and designed for floor mounting, incorporating switch operation as standard but with the advantage of microprocessor option.

The one piece galvanised tank base ensures longevity of this equipment.

The tank is fitted with a 15mm float valve with a specially designed extended ball arm, for system water make-up. A 32mm overflow and weir maintain “AB” backflow prevention.

The twin pump version includes an automatic change-over relay ensuring even pump wear, together with standby facility.

A suitably sized solenoid valve is fitted to deal with system expansion.

A small 8 bar rated diaphragm vessel is included within the package for control purposes.

High/Low pressure switches are fitted for remote BMS monitoring as standard.

The units are fully packaged and require no extra expansion vessel.

LAYOUT

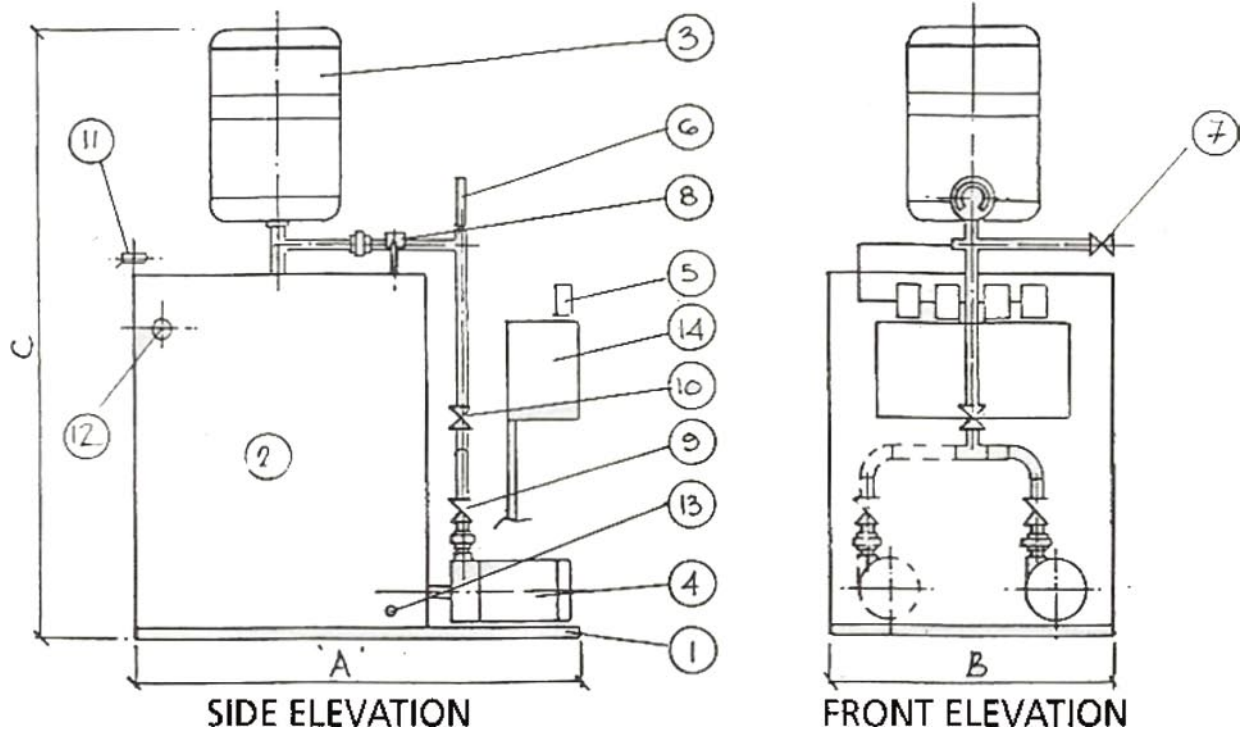

ITEM	DESCRIPTION
1	Base
2	Spill Tank
3	Pressure Vessel
4	Pumps
5	Pressure Switches
6	Pressure Gauge
7	System Valve 3/4"
8	Solenoid Valve
9	Non-Return Valve
10	Control Valve
11	Ball Valve 1/2"
12	Overflow Socket
13	Drain 1/2"
14	Control Panel

SELECTION TABLE

UNIT TYPE	No. OF PUMPS	L.P.H.W System, Content	C.H.W System, Content	O/A	O/A	O/A
				"A"	"B"	"C"
SA10-P-1	ONE	730	3960	840	330	1070
SA10-P-2	ONE	1423	7400	840	480	1150
SA10-P-22	TWO	1423	3700	840	480	1150
SA10-P-3	ONE	2654	13800	1000	480	1150
SA10-P-32	TWO	2654	13800	1000	480	1150
SA10-P-4	ONE	4422	23000	1000	630	1310
SA10-P-42	TWO	4422	23000	1000	630	1310
SA10-P-5	ONE	8845	46000	1000	630	1600
SA10-P-52	TWO	8845	46000	1000	630	1600
SA10-P-6	ONE	13270	69000	1300	630	1600
SA10-P-62	TWO	13270	69000	1300	630	1600

TYPICAL PIPEWORK & ELECTRICAL CONNECTIONS

INSTALLATION AND OPERATION

Once the unit has been installed correctly on the return leg, prior to the boiler/chiller and a suitable distance from the circulation pump, so as not to cause any artificial back pressure, ensure that the spill/fill tank has a water supply and that the pumps are purged of all air.

Operation

Pressure is maintained in the system by the pump/s which are controlled by the pressure sensor.

Contraction or loss of water from the system will bring the duty pump into operation.

Alternatively, with an increase in pressure due to expansion the water from the system is initially taken up in the nitrogen charged pressure vessel after which a solenoid valve operates to discharge the system water into the spill tank.

There are six standard spill tank sizes in the range and the selection is dictated by the total water content of the system.

If in doubt please call one of our regional offices for advice in sizing the correct type of equipment for your installation.

Standard power supply is 230/1/50. 400/3/50 is available.

Additions, if required:

- Pump trip indication
- High/Low pressure lamps
- High/Low pressure audible alarm
- Hour run meters

The information in this specification is correct at time of issue; As AquaTech Pressmain design and development programmes are continuous, we reserve the right to make any changes to this specification without prior notice.



Head office

AGM House, London Road, Copford, Colchester. CO6 1GT
T: 01206 215121 F: 01206 215131

Manchester Office

Dolphin House, 130 Princess Road, Manchester. M16 7BY
T: 0161 226 4727 F: 0161 226 5848

E: info@aquatechpressmain.co.uk

W: www.aquatechpressmain.co.uk