

AquaTech Pressmain



MICROMATIC - VARIMATIC - AQUAMATIC

Cold Water Pressure Booster Set Accessories

Cold Water Pressure Booster Set Accessories

DIAPHRAGM VESSELS

HYDRAULIC ACCUMULATORS, DOMESTIC HOT WATER SERVICE & LTHW

AQUATANK 'VR' Series:

WRAS approved, Meets or exceeds EC norms for pressure vessels 97/23/EC

Max working pressure: 10 bar (15 bar available on request)

Replaceable diaphragm and coating of all parts in contact with water in conformity with the food stuffs regulations, water in bag.

Application Range:

Potable water supply systems; Fire extinguishing systems; Pressure booster systems; Pressurisation sealed expansion systems; Sprinkler systems; Water shock arresters.

Construction and Materials:

Vessel: Steel RSt 37-2.

All vessel parts in contact with water are coated against corrosion.

Diaphragm: Made of special high quality rubber material suitable for potable water applications according to the prevailing regulations and recommendations.

Filling Valve: Schraeder-valve-type.

Surface Treatment: Blue, durable powder coating finish.



Type	8 RS	25 HR	60 VR	100 VR	200 VR	300 VR	500 VR
Nominal Content –litres	8	25	60	100	200	300	500
D mm	206	295	409	480	634	634	740
D1 mm	-	228	-	-	-	-	-
H mm	320	485	740	840	980	1280	1485
Water Connection DN BSP	3/4"	1"	1"	1"	1 1/4"	1 1/4"	1 1/4"
Weight Kg	2.4	5.6	25	32	50	55	85
Max. working Pressure-bar	10	10	10	10	10	10	10

Datasheet 403m

SA16 SHOCK ARRESTER

Stainless Steel Construction with fixed diaphragm.

Suitable for potable water (UK WFBS listed).

For use as a shock arrester to prevent water hammer due to the sudden arrest of waterflow by the quick closing action of valves or taps. The installation of a mini vessel close to the tap or valve reduces the over-pressure of the system to acceptable levels by absorbing the water impact with the air cushion.

The recommended pre-charge pressure is 1.5 bar.

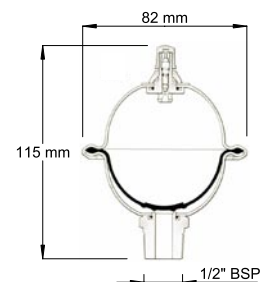

Also suitable for use as a mini expansion vessel as an integral component of a domestic water heating appliance. Pre-charge pressure as heating appliance manufacturer's specification - maximum 10 bar.

CUSTOM MADE COPPER DISTRIBUTION MANIFOLDS

Custom made Copper distribution manifolds suitable for potable water distribution, pre assembled with any number of available options.

Available in lengths upto 2 metres and diameters up to DN150, with installer specified connections. Each stabbing can include: Isolating valve, Water Meter, Double Check Valve, Pressure Reducing Valve, RPZ Valve, Drain off Point, or any other required device.

Assembled using WRAS Approved components, in compliance with the Pressure Equipment Directive, using Copper to EN 1057. Every Manifold is Pressure Tested for leaks after manufacture.



Also Suitable for use as headers in Heating systems

Datasheet 503m

PRESSURE REDUCING VALVES

JRG Pressure Reducing Valve

For Domestic and Industrial applications

Sizes: 15mm (1/2") – 65mm (2 1/2")

- Positive drip tight shut-off at zero flow
- Accurate outlet pressure
- Stainless steel internals
- 25 Bar pressure rated
- Adjustment range: 0.5 – 10 bar



Shown with optional pressure gauge

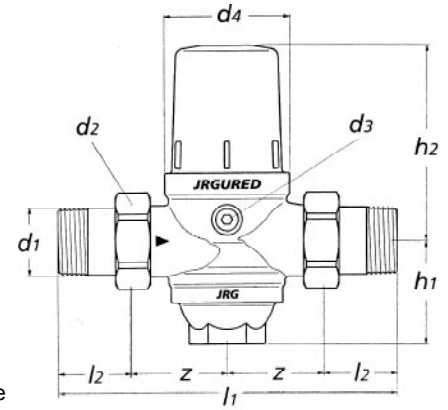

The JRG series 1300 is a WRAS approved compact fitting for water systems. Consisting of a pressure reducing valve and integral strainer, it is designed to automatically maintain a constant outlet pressure irrespective of fluctuations in inlet pressure and / or flow. When downstream pressure exceeds the pressure setting, the valve will close drip tight with zero creep. The valve is also suitable for regulating air and inert gases.

JRG Dimension Table											
Nominal size		Dimensions [mm]									Weight
mm	Inches	d1	d2	d3	d4	l1	l2	Z	h1	h2	Kg
15	1/2"	R 1/2	G 3/4	Rp 1/8	52	148	34	40	28.5	78.5	0.72
20	3/4"	R 3/4	G 1	Rp 1/8	58	159	37	42.5	35.5	85.5	0.98
25	1"	R 1	G 1 1/4	Rp 1/4	70	184	42	50	51.5	110	1.8
32	1 1/4"	R 1 1/4	G 1 1/2	Rp 1/4	77	212	46	60	64	120.5	2.65
40	1 1/2"	R 1 1/2	G 1 3/4	Rp 1/4	93.5	241	48	72.5	80	157	4.44
50	2	R 2	G 2 3/8	Rp 1/4	103	289	57	87.5	98	172	6.8
65	2 1/2"	R 2 1/2	G 3	Rp 1/4	103	310	65	90	98	172	8.07

Cla-Val series 90-01 Pressure Reducing valve

For Commercial and heavy Industrial applications

- Extremely accurate control of set-point
- Positive drip tight shut-off at zero flow
- Exceptional reliability
- Adjustable over a wide range of pressures



Shown with optional pressure gauges

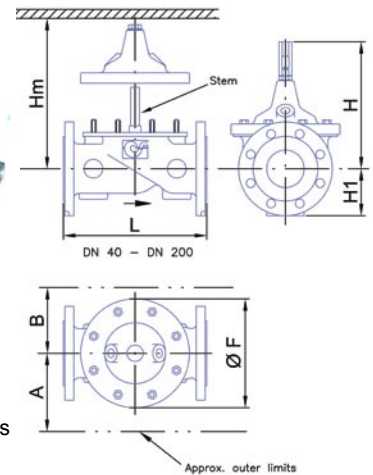

The Cla-Val model 90-01 is a WRAS approved hydraulically operated, pilot controlled, modulating valve designed to maintain a constant downstream pressure to a pre-determined value despite fluctuations in mains pressure and/or flow-rate. When downstream pressure exceeds the pressure setting, the main valve and pilot close drip tight. Please contact our sales team for sizing information.

Cla-Val Dimension Table									
Nominal Size	Dimensions [mm]								Weight
Flanged (mm)	L	F	H	H1 (PN 10-16)	H1 (PN 25)	HM	A	B	kg
DN50	280	170	215	82.5	82.5	285	150	100	20
DN 65	305	205	245	93	93	320	165	115	25
DN 80	381	235	260	100	100	345	203	127	30
DN 100	508	295	345	110	117.5	450	216	152	50
DN 150	645	400	415	142.5	150	540	230	205	95
DN 200	645	510	495	170	180	645	285	260	170

AQT SERIES 1 PIECE 2 PIECE OR SECTIONAL GRP BREAKTANKS

AquaTanks are moulded in one piece using GRP materials as approved by the Water Regulations Advisory Scheme. Built to BS EN 13280.2001. All tanks and lids are pre-insulated with 25mm (.85/mil°C) C.F.C free foam fully encapsulated within the laminates as standard. 50mm and 75mm insulation is also available on request. All tanks comply with Water Supply Regulations 1999 (Fluid category 5), incorporating a Type 'AB' air gap with a raised float valve chamber with screened mesh slots/weir overflow.

All tanks are in light grey to BS5252.

'AQT' SERIES ONE PIECE G.R.P. BREAKTANKS Datasheet 501					
Tank Reference	Nominal Capacity		Appr. Actual Capacity		External Dimensions (mm)
	Litres	Gallons	Litres	Gallons	L x W x H (Inc. Valve Box)
AQT20	90	20	65	14	775 x 475 x 900
AQT35	160	35	110	24	935 x 630 x 840
AQT50	225	50	170	37	780 x 780 x 990
AQT75	340	75	250	55	1085 x 785 x 990
AQT100	454	100	350	77	1220 x 750 x 1090
AQT125	570	125	440	97	1135 x 900 x 1140
AQT150	680	150	485	107	1380 x 1075 x 990
AQT200	909	200	740	163	1308 x 1030 x 1270
AQT250	1135	250	840	185	1705 x 1085 x 1255
AQT300	1364	300	1045	230	1530 x 1252 x 1355
AQT350	1590	350	1220	268	1705 x 1315 x 1355
AQT400	1818	400	1510	332	1380 x 1380 x 1660
AQT500	2272	500	1784	392	1990 x 1380 x 1456
AQT600	2726	600	2239	492	1990 x 1380 x 1600
AQT700	3185	700	2542	560	2600 x 1380 x 1510
AQT800	3636	800	2990	657	2600 x 1380 x 1760
AQT1000	4535	1000	3773	830	2600 x 1684 x 1760
AQT1200	5440	1200	4478	986	2600 x 1988 x 1760



OPTIONAL STEEL UPSTAND

As shown above, our steel upstand assemblies are provided with a PLY insert to spread distribute the tank weight over its area. The assembly can be fabricated to any height to suit site conditions and be supplied dismantled for ease of site access. Please discuss your requirements with the sales team.



SECTIONAL TANKS

AquaTech Sectional storage tanks are manufactured in a modular format, which allows virtually any size and configuration of tank. The individual panels are assembled using closed cell sealant materials and fixed using A4 grade stainless steel fixings. Panels are manufactured from high quality SMC material hot pressed moulded to a temperature of 150°C. ensuring maximum dimensional stability in a metric format, panels being 1000 x 1000mm, 1000 x 500mm & 500 x 500mm. Individual panels are dimensionally accurate with defined sharp corners, and are precision factory drilled. Truncated Base panel option for maximum strength and to provide self-draining facility. Factory Pre-insulated using 25mm CFC free polyurethane foam providing a U value of 0.83 n/m². Fully WRAS approved and manufactured under ISO 9002 approved quality system.

“MG” SMART RELAY TANKMATIC RANGE

- Level and/or Temperature Measurement
- Single Tank Monitoring
- LCD Backlit Display
- BMS Volt Free Outputs
- High and Low level Alarm
- Wall Mounted IP55 Rated Enclosure
- Built to Latest CE Requirements and in accordance with our ISO9001 Quality System.
- De-stratification Option Available



Datasheet 402m MG

TANK LEVEL MONITORING SWITCHES

LSM TANK LEVEL SWITCH

- Continuous low and/or high level monitoring
- Available for use with conductivity level probes or float switches
- Can be interlinked with AquaTech Pressmain control panels
- 1(-A) or 2(-B) Volt Free Relay (240 VAC 3 Amp) outputs to remote alarm or booster cut-out interlock
- IP54 Rated enclosure. - For tank lid or wall mounting
- Built to latest CE requirements in accordance with ISO9001 quality system

Model Shown LSM-P3 with integral 1 metre conductivity probes

Datasheet 401



LSM-P3

MSF-100 PLASTIC LEVEL SWITCH

- Tank Lid Mounting
- Ideal for water & sewage
- Supplied with 10 metre cable
- Other cable lengths available
- Adjustable counter-weight
- Easy to install
- Single volt free switch with normally open & normally closed contacts
- Max Current: 10A 250V cos φ 1 - 4A 250V cos φ 0.6



MSF-100

LW3 CONDUCTIVITY LEVEL PROBE

- 304 Stainless Steel conductivity probe
- Tank Lid Mounting
- Supplied with 5 metres of cable
- Other lengths available on request
- Easy to install
- Can be connected directly to AquaTech Pressmain control panels to stop booster set before air can enter suction pipework and / or for optional high level alarm on HY sets



LW3

MSL-104 STAINLESS STEEL FLOAT SWITCH

- 304 Stainless Steel construction
- Tank Side entry (External Fit into 1/2" BSP boss)
- Suitable for water, sewage, acid & alkaline liquids
- Can be connected directly to AquaTech Pressmain control panels to stop booster set before air can enter suction pipework and / or for optional high level alarm on HY sets



MSL-104

LSM-TT-B TWIN TANK LEVEL PROTECTION SWITCH

- Continuous twin tank low or high level monitoring
- Available for use with conductivity level probes or float switches (see options over)
- Individual tank isolation service switches
- 1 BMS volt free relay output per tank to remote alarm or Booster cut-out interlock
- IP54 Rated enclosure - For wall Mounting
- Built to latest CE requirements and in accordance with ISO9001 quality system
- Optional remote visual & audible alarm panel



LSM-TT-B

NOISE AND VIBRATION

Flexible Connections

Made from EPDM rubber suitable for potable water applications, this spherical bellows type flexible coupling joint will absorb pipe movements, isolate vibration, reduce system noise and help to protect plant against start up surge forces.

Gaskets are not required and the joints are easily and speedily installed. System pipework mating flanges are available upon request.



Anti Vibration Mountings

When fitted this turret type mount will isolate the pump package from the ground or floor-mounting surface. The mounting will arrest and reduce pump rotation starting inertia and associated vibration being transmitted through the ground or floor-mounting surface, which could potentially cause a noise problem.



Acoustic Attenuator Enclosure

Although the standard package meets stringent EC noise levels, this enclosure is specifically designed for noise sensitive applications. Typically an insertion loss of approximately 30dB(A) can be achieved in most applications. Enclosures are supplied complete with naturally ventilated acoustic louvres, removable panels for easy pump maintenance and glazed vision panel for viewing pump controls fascia.

Typical Enclosure Details

Enclosure constructed from Noisheld™ Regular panels assembled onto pre-fabricated frame
Internal & External finish: Natural Galvanised. Enclosure supplied in kit form for site assembly.

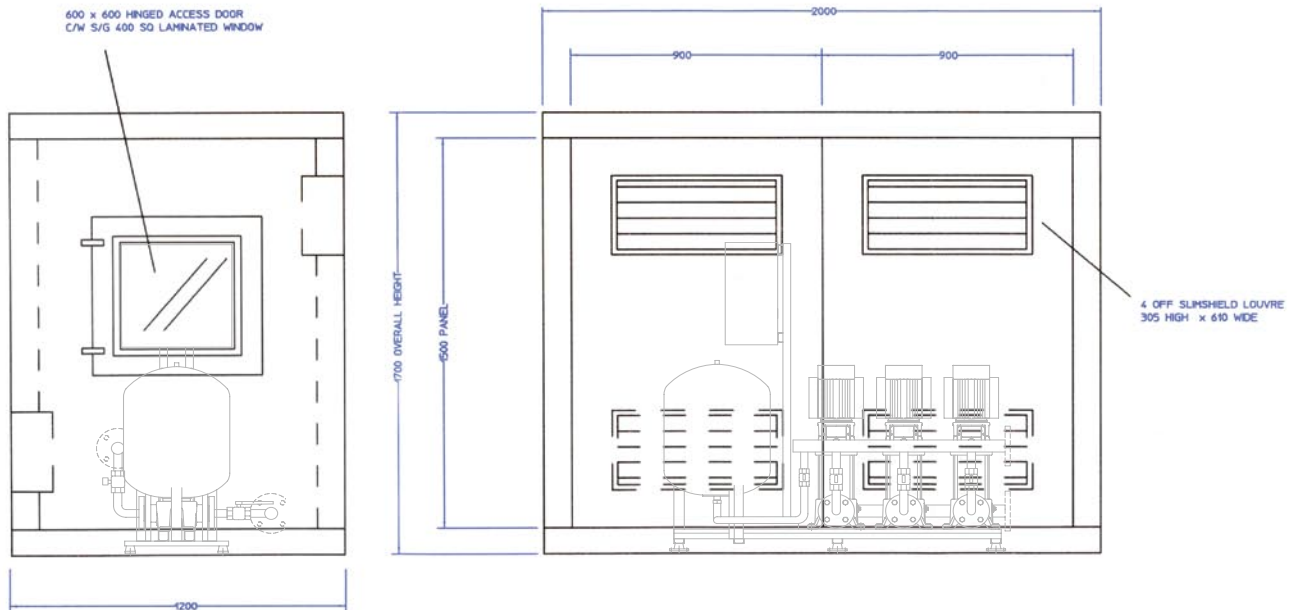

CONTROL PANEL OPTIONS

Custom Control Systems

AquaTech Pressmain can build one-off control systems to suit specific site demands. Examples of these include a twin pumpset 24hour changeover panel which enables two complete pumpsets to be used in a duty/standby arrangement. The duty is shared between the pumpsets and is automatically swapped every 24 hours. Should one pumpset develop a fault the other is automatically started and an alarm sounded. Other custom panels have included: Fan controllers, Boiler sequencing units, sump pump controllers and level sensor controlled transfer units.



CONTROL PANEL OPTIONS

FORM 4 STYLE Compartmented Control Enclosures

AquaTech Pressmain have experience of building FORM 4 style compartmented enclosures for pumpsets with separate compartments for the Incoming supply, Control assembly, Pump overloads and Pump starters. The exact specification of any panel will be discussed with our sales and technical teams prior and during application.



Individual Pump isolators

In critical building services or process installations, individual pump isolators can be fitted to the control panel enabling the pumps to be serviced, or even removed without having to isolate the whole pumpset.

4-20mA Pressure Output Module

This output module enables remote monitoring of the pumpset's output pressure using an industry standard 4-20mA electrical signal.

Emergency Stop Button

Where required an emergency stop button can be provided on the control panel, which when pressed will cut-out the controller stopping all of the pumps.



2020+ Micro Controller

Our 2020plus micro controller is a direct replacement for the 2000+ and comes with all of the features of the 2000+ controller, but also includes enhanced variable speed pump control to ensure smoother speed changes, a fault log displaying the last ten faults with time and date as well as the RE-PRESS power restoration electronic safety system offering the user a controlled system refill following electrical or supply water failure.

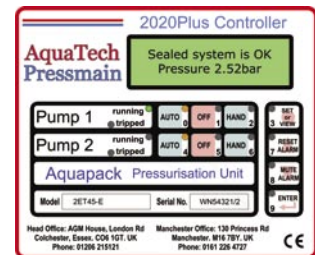

Anti-Condensation Panel Heaters

If your set is to be installed in a cold or damp environment you may wish to consider an anti-condensation heater with thermostat. This will prevent moisture build up within the panel, which can cause malfunction or even failure of the control system.



HY LED Remote Indication Panel

The Remote Alarm Panel gives a visual (type A) and audible (type B) indication of a variety of pumpsets faults the nature of which is easily determined via 10 user definable LED's.



RA 24/240 REMOTE Audible / Visual Alarm

The RA remote alarms are designed for easy installation and can be installed anywhere to supply a Audio/Visual warning of pumpset faults. They can work on 24V AC/DC or 240VAC, and so can easily use any existing power source, or be connected to the control circuitry of some of our panels. They also feature adjustable tone and volume, and are protected to IP54.



PUMPSET OPERATION MODES

-ET- (ELECTRONIC TRANSDUCER) PUMPING PRINCIPLE

Most AquaTech Pressmain Cold Water Pressure Booster Sets are transducer controlled. Using pressure transducers is a much more reliable and accurate way of controlling water pumps than using pressure switches. Transducers allow microprocessors to control which pump is started so that the duty is more evenly distributed among the pumps; this not only means that all of the pumps wear evenly but ensures that the water quality within the pumps is maintained. The pumpset can also be adjusted to match the customers' requirements, either by increasing the pump differential to reduce pump starts or by reducing it to provide a much more consistent pressure. Our standard range of -ET- pumpsets all utilise fixed speed pumps.

-AV- (ALL VARIABLE SPEED) PUMPING PRINCIPLE

The basic concept is to alter the pump speed to match exactly the required demand of water to the system, using the principle that flow rate is directly proportional to pump speed. The electricity consumed by the pump motor is proportional to the cube of the pump speed. It can be shown (Fig. 1) that a 20% reduction in flow rate from the peak demand will reduce the power consumed by the motor by 50%. As the flow demand continues to decrease further savings in pump motor power consumption can be achieved.

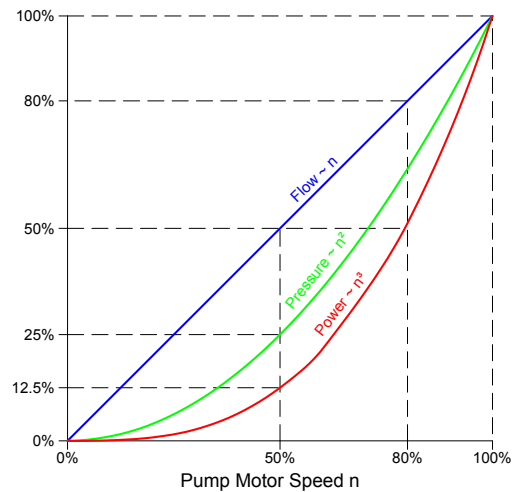

Not only does this produce a saving in electricity consumption but it also provides other benefits such as reduced strain on the pumpset and system components caused by excessive pressure and water hammer, while ensuring smoother and quieter operation through "ramped" acceleration and deceleration of the pump.

-L- LEAD PUMPING PRINCIPLE

The idea behind lead pumpsets is to use a smaller pump to meet the demand during times of low usage, and then to use larger support pumps when peak demand occurs. This type of pumpset is best suited to an application where the peak demand is in great contrast to the normal demand. Examples of places where this idea has been put to good use are sports stadiums (such as Wimbledon Centre & Number 1 Courts where the water supply is provided using AquaTech Pressmain cold water booster sets) where demand is often low but at times such as match intervals or pitch watering, the demand is at a peak. This concept can be applied to any building where there is a large fluctuation in the demand for water. This option can be used with either fixed or variable speed pumps.

The information in this specification is correct at time of issue; as AquaTech Pressmain design and development programmes are continuous, we reserve the right to make any changes to this specification without prior notice.

AquaTech Pressmain

Head office
AGM House, London Road, Copford, Colchester. CO6 1GT
T: 01206 215121 F: 01206 215131

Manchester Office
Dolphin House, 130 Princess Road, Manchester. M16 7BY
T: 0161 226 4727 F: 0161 226 5848

E: info@aquatechpressmain.co.uk
W: www.aquatechpressmain.co.uk

Leaders in the design, manufacture and assembly of packaged fluid pumping equipment and control systems.
Applications: Cold Water Supply; Fire Fighting; Heating & Chilled System Pressurisation; Tank Level Monitoring.