

AQUATANK 'VR' SERIES DIAPHRAGM EXPANSION VESSELS

Expansion Vessels VR Series:

The expansion vessels for special applications.
WRC approved.

Meets or exceeds EC norms for pressure vessels 97/23/EC

Max working pressure: 10 bar

Replaceable diaphragm and coating of all parts in contact with water in conformity with the food stuffs regulations, water in bag.

Application Range:

Potable water supply systems, Fire extinguishing systems; Pressure booster systems; Pressurisation sealed expansion systems; Sprinkler systems; Water shock arrestors.

Construction and Materials:

Vessel: Steel RSt 37-2.

All vessel parts in contact with water are coated against corrosion.

Diaphragm: Made of special high quality rubber material suitable for potable water applications according to the prevailing regulations and recommendations.

Filling Valve: Schraeder-valve-type.

Surface Treatment: Blue, durable powder coating finish

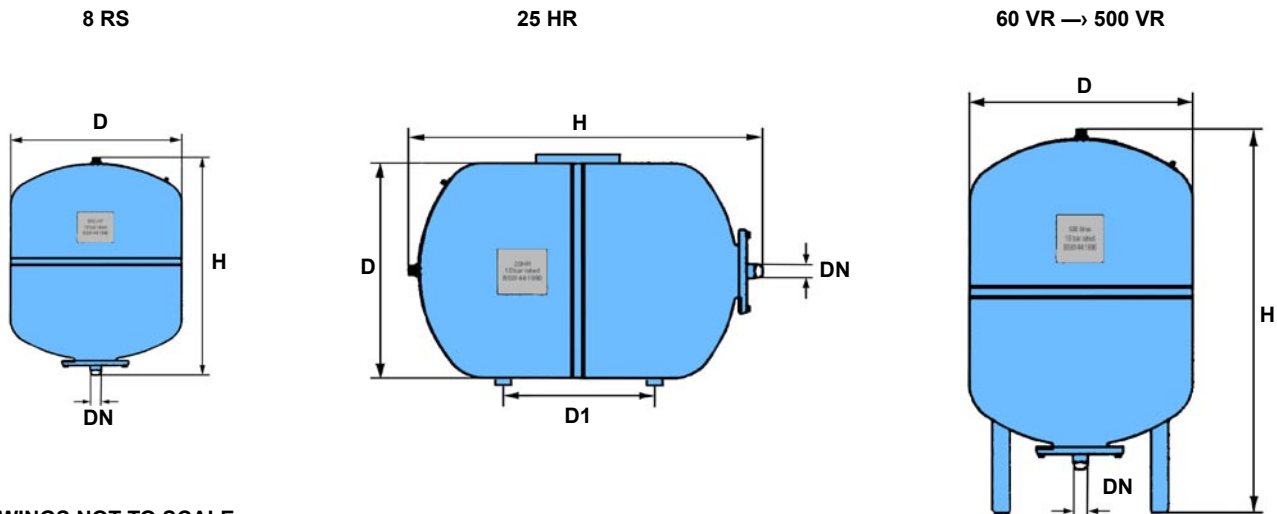

DRAWINGS NOT TO SCALE

Type	8 RS	25 HR	60 VR	100 VR	200 VR	300 VR	500 VR
Nominal Content –litres	8	25	60	100	200	300	500
D mm	206	295	409	480	634	634	740
D1 mm	-	228	-	-	-	-	-
H mm	320	485	740	840	980	1280	1485
Water Connection DN BSP	¾"	1"	1"	1"	1 ¼"	1 ¼"	1 ¼"
Weight Kg	2.4	5.6	25	32	50	55	85
Max. working Pressure-bar	10	10	10	10	10	10	10

INSTALLATION:

Install with isolation valve and drain-off cock. The connection pipe to the expansion vessel should have a corresponding diameter. Unnecessary friction losses should be avoided. Set up vessel so that the air charge filling valve and the diaphragm (top and bottom of vessel) are accessible for future maintenance. Set air cushion pre-charge pressure to correct level, dependent upon application required for vessel. Refer to AquaTech Pressmain for advice.

ADJUSTING THE PRE-CHARGE PRESSURE:

Isolate vessel from system and release pressure on water side (by opening drain cock). Keep drain cock open during air charging process. The water inside the bladder will be pushed back by the charge pressure. Remove cap on filling valve. Set air charge pressure accordingly, refilling using dry air or nitrogen. Screw cap firmly on filling valve. Close drain cock and open water connection to system. Air must not be vented from the air valves of these vessels, except for adjustment of the cushion pressure.

REPLACEMENT OF DIAPHRAGM: (except for 8 ltr. vessels where the complete vessel should be replaced)

1. Isolate vessel from system. Drain water from vessel using drain cock.
2. Release air charge pressure before removing water connection flange "A"
3. Disassemble diaphragm "B" by removing nut "C" on dished end "D".
4. Remove diaphragm "E" from inside the bottom opening.
5. Check vessel for dirt, corrosion, etc. Remove or flush with water. Vessel should be dry when putting in replacement diaphragm. The diaphragms are not oil resistant and oily liquids must not be used to protect the inside surfaces of tanks against corrosion.
6. Put support "B" in diaphragm and roll up diaphragm "E" in the longitudinal axis.
7. Fix screw M8 to diaphragm support "B" and pull the diaphragm by means of a rope into the vessel as far as the fixing opening on top.
8. Fix support "B" with nut "C" and close vessel by replacing flange "A".
9. Re-fill charge pressure using, for example, using dry air or nitrogen. Check vessel for leaks and connect to the system again.

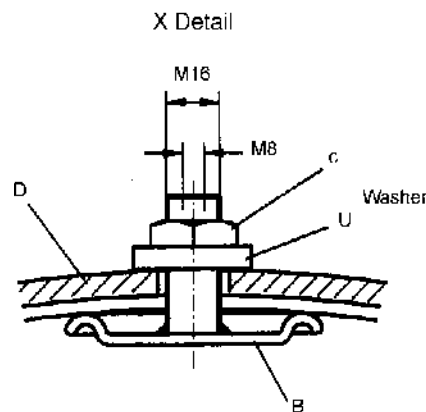
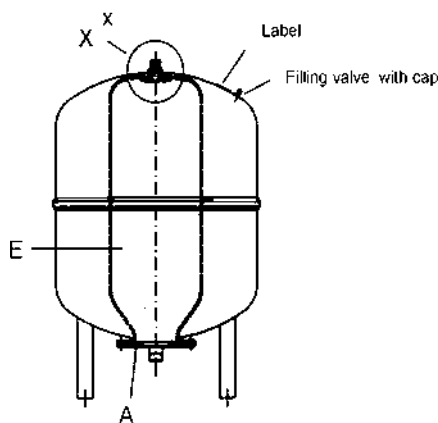

MAINTENANCE: (Pre-Charge Pressure and Inspection)

The correct charge pressure guarantees reliable operation of the system and a prolonged lifetime of the diaphragm. The diaphragm pre-charge must be checked on a regular basis (6 months is recommended) see method above. To comply with current legislation ("Pressure Systems & Transportable Gas Container Regulations 1989") and insurance cover requirements, it may be necessary to carry out a regular inspection of accumulator or expansion / control vessels (generally 250 bar / litre vessels and greater).