



AquaTech Pressmain

**WORLD CLASS
HEATING & CHILLED SYSTEM PRESSURISATION UNITS**



AQUASPILL GV100-E, TA100-E & AS2AV SERIES



“AQUASPILL” GV100-E, TA100-E & AS2AV

Multi-Pump Spill- Back Pressurisation Unit with 2020+ Microprocessor Controller.

GENERAL

The Aquaspill GV100-E, TA100-E and AS2AV system pressurisation units automatically maintain pressure in pressurised heating or chilled water systems which have total water content between 240,000 litres at 60°C boiler flow temperature and 68,000 litres at 120°C for standard units, unlimited system content for special units, boiler flow temperatures up to 120 degrees centigrade and cold fill pressures up to 8.0 bar. Larger systems can also be designed for, please ask AquaTech-Pressmain for further details.

To save valuable floor space the “TA100” units have the spill tank mounted above the pump module.

Once the system has been initially filled via a quick filling loop (part No. MAF-200001) the “Aquaspill” will take over and maintain optimum system conditions.

On rising system temperature the expanding water is spilled automatically into spill tank/s, and as the system cools the spilled water is automatically pumped back into the system. Any loss of water from the system will be automatically made-up.

During the above operations the pressure variation does not normally exceed 0.6 bar.

GV & TA units have fixed speed pumps, AS-AV units have variable speed pumps.

SPECIFICATION

Aquaspill type GV100-E/TA100-E (or AS2AV) suitable for an estimated system volume of AAAAA litres having a cold fill pressure of BB bar, incorporating 2020+ microprocessor and pressure transducer control, with twin single phase (or 3 phase) pumps having automatic alternation of duty pump & anti seizure pulsing, delayed initiation of high and low system pressure cut outs both linked to single pole volt free relays, hand-Off-Auto switches for each pump, pump Run & Tripped L.E.D.s, hours run meters, interlocked door isolator, low water level sensing in Spilltank coupled to volt free relay, alarm buzzer, alarm mute and reset buttons/indicators, digital pressure, fault and parameter indicator. Combined spill and mains water break tank, float valve with type AB air gap, overflow connection, and low water level protection, electromagnetic spillvalve with strainer & isolating valves, IP55 powder coated control cabinet, interconnecting piping to spill tank, all mounted on steel base frame. Set assembled, tested and commissioned in accordance with ISO9001 Standards & Pressure Equipment Directive.

OPTIONAL AQUASPHERE BLANKET

This is a single layer ball blanket which floats on the spill tanks' surface, which will significantly reduce liquid evaporation & oxygen ingress.

A National Engineering Laboratory study showed a reduction in evaporation of over 80% when compared to a tank without an Aquasphere blanket. Absorption of free oxygen into hot water contained in open spill tanks can lead to serious corrosion of pipes, valves and boiler jackets. Tests have also shown that a single layer blanket can reduce oxygen absorption by up to a factor of 20. The Aquasphere Blanket system can therefore be seen as a highly effective two way barrier preventing both evaporation from and absorption into a liquid.

STANDARD FEATURES:

- Maximum expanded volume (acceptance): normally 4,000 litres; maximum system cold fill pressure: 8.0 bar. (Larger systems also available)
- An intermediate cooling vessel can be used if boiler flow temperature exceeds 90°C.
- Automatic alternation of duty pump to even wear.
- Anti pump-seizure pulsing.
- Low water level pump protection switch mounted in Spilltank.
- Automatic delay on high & low pressure alarms up to 4 minutes to allow circulator pump pressures to stabilise.
- Ideal for system refurbishment where pressure rise must be minimised, and floor space is at a premium.
- Integral automatic water make-up system.
- Designed, manufactured & tested to ISO9001 Standards.
- Full commissioning and after sales service available nationwide.
- CE marked for full compliance with all relevant European Directives.
- Optional M & E 3 specification.
- Optional High water level alarm switch mounted in Spilltank.

OPTIONAL EXTRA ECO-FRIENDLY FEATURES:

- Increasing the size of the control vessel will reduce the spilling/pump back frequency and reduce energy consumption thereby reducing carbon footprint.
- Adding or increasing the size of cooling vessel will lengthen the life of the control vessel and reduce thermal stress on pumps and pipework thereby increasing their working life.
- Adding an Aquasphere blanket will considerably reduce evaporation of system water and oxygen absorption, significantly reducing water loss & system corrosion, therefore prolonging system life.
- Variable speed operation of spill pumps will reduce energy consumption (and carbon footprint) and reduce strain on system components.
- Pre-heating spill back water will reduce thermal shock in boiler and hence reduce corrosion lengthening boiler life.

AQUASPILL SELECTION FOR HEATING SYSTEMS:

- 1) In order to select the correct pressurisation unit, firstly calculate the required **Cold Fill** pressure. i.e. the minimum pressure that is required to ensure the entire system is filled with water and does not flash over to steam at higher flow temperatures (the superimposed pressure).

The **Cold Fill** pressure is calculated by:-

- a) adding the static height of the system (i.e. height in metres above the pressurisation unit to the highest point of the heating system) then converting this height into Bar (10.2 metres equals 1.0 Bar)
- b) adding the Superimposed pressure from Table 1 (dependent upon boiler flow temperature)
- c) and adding 0.6 Bar for pump switching differentials.

Boiler Flow Temperature °C	Expansion of system water in percent %	Superimposed pressure required in Bar.	
40	0.78	0.2	Warm Water Heating System (e.g. Heat Pump or Condensing Boiler)
50	1.21	0.2	
60	1.71	0.2	
70	2.28	0.2	Low Temperature Hot Water "LTHW"
80	2.91	0.2	
82	3.05	0.2	
90	3.60	0.2	
95	4.0	0.3	
100	4.35	0.5	Medium Temperature Hot Water "MTHW"
110	5.15	1.1	
120	6.01	1.8	

Table 1: Note: MTHW systems require a Cooling vessel.

Example 1) A system with a static height above the pressurisation unit of 4 metres and a flow temperature of 82°C, would result in: -
 Cold Fill Pressure (Bar) = 0.4 (static height in Bar) + 0.2 (superimposed pressure) + 0.6 (pump differentials)
 Cold Fill Pressure = 1.2 Bar.

Example 2) A system with a static height above the pressurisation unit of 10 metres and a flow temperature of 120°C, would result in: -
 Cold Fill Pressure (Bar) = 1.0 (static height in Bar) + 1.8 (superimposed pressure) + 0.6 (pump differentials)
 Cold Fill Pressure = 3.4 Bar.

- 2) The **High Pressure Alarm** point would under normal circumstances be set to 1.0Bar above the Cold Fill Pressure. This may be increased or possibly decreased for special systems or applications. Please refer to AquaTech Pressmain for further advice.

Cont. next page.....

AQUASPILL UNIT STANDARD PERFORMANCE RANGE:

- 3) For standard **Pump Module** performance range, see the chart below. For specific pump selection or if the selection falls outside of the range of this chart then please contact your nearest AquaTech-Pressmain office for special pumps.

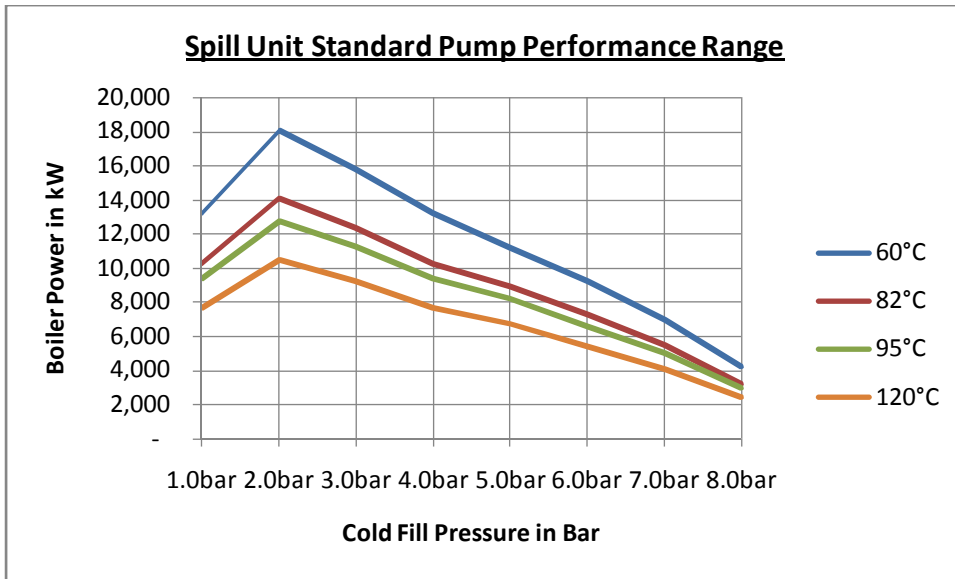

Chart 1: Spill unit standard performance range

- 4) The limits of standard sized **Spill Tanks** is shown in the chart below. If your system falls outside of the range of this chart then please contact your nearest AquaTech-Pressmain office for special tanks which can be built to any required dimensions.

In order to select the correct spill tank, it is necessary to know the **System Content** of water in litres. If this is not known then an estimate of 10 litres per kilowatt of boiler power may be used subject to customer confirmation by calculation or measuring the actual content when the system is filled.

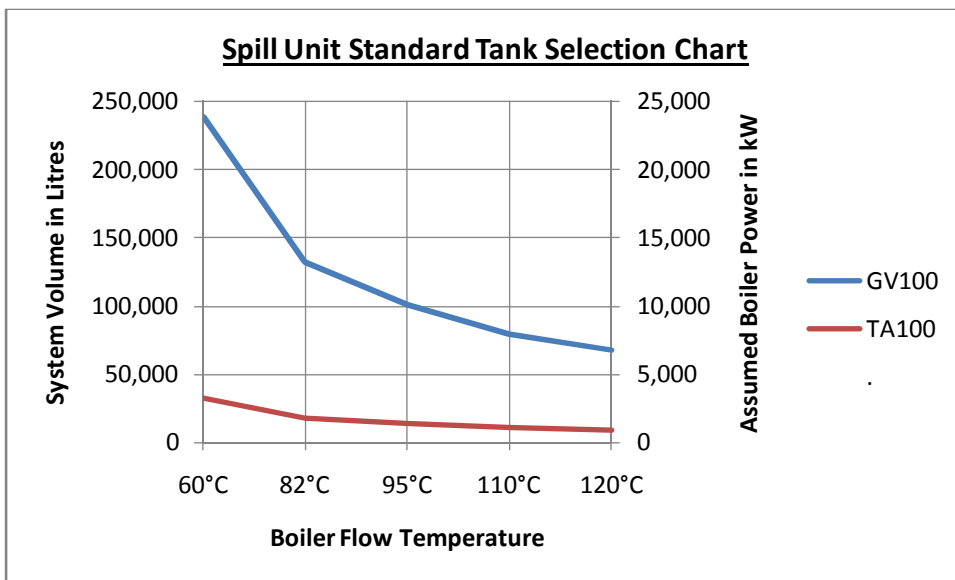

Chart 2: Spill unit standard Tank selection chart

Note: An intermediate cooling vessel can be used if boiler flow temperature exceeds 90°C.

GENERAL ARRANGEMENT DRAWING FOR AQUASPILL GV100-E UNITS:

Examples of the general arrangement for a GV100-E pressurisation unit is shown below, although all units are manufactured to suit site conditions/requirements so actual layout and dimensions will differ from that shown. Please contact AquaTech-Pressmain for details.

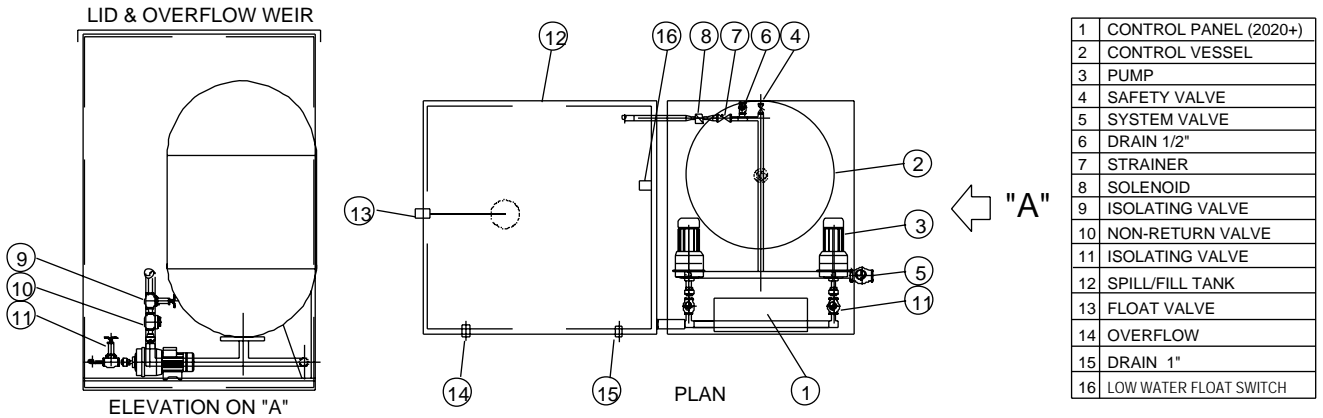

Fig 1: Typical arrangement showing "GV100-E" with twin pumps and spill tank.



Fig 2: Typical example of a GV100-E pressurisation unit.

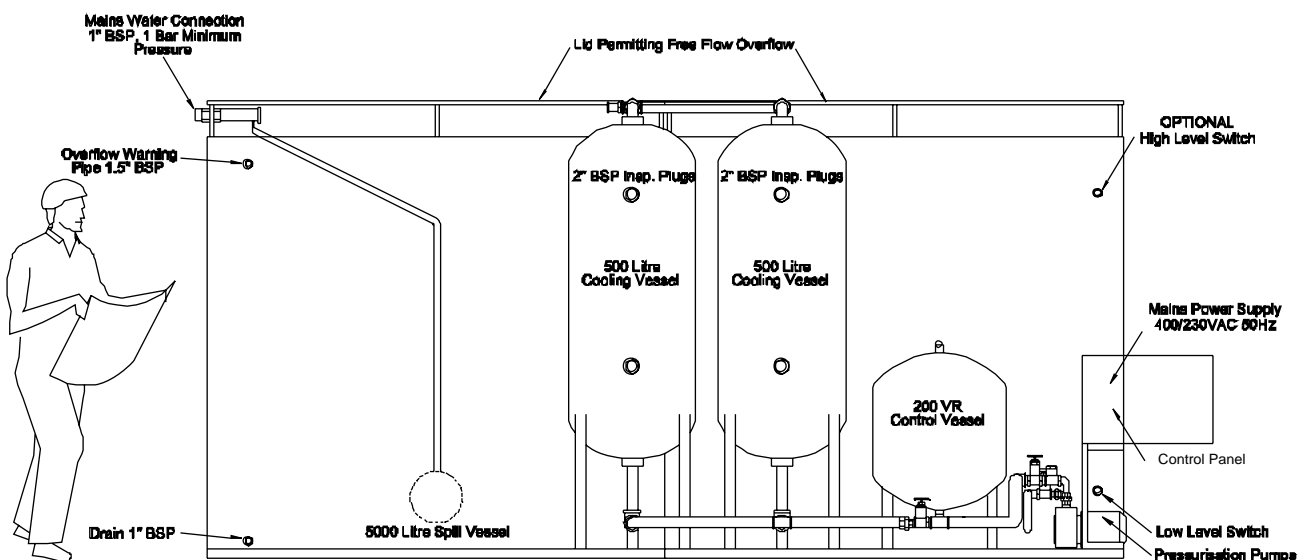
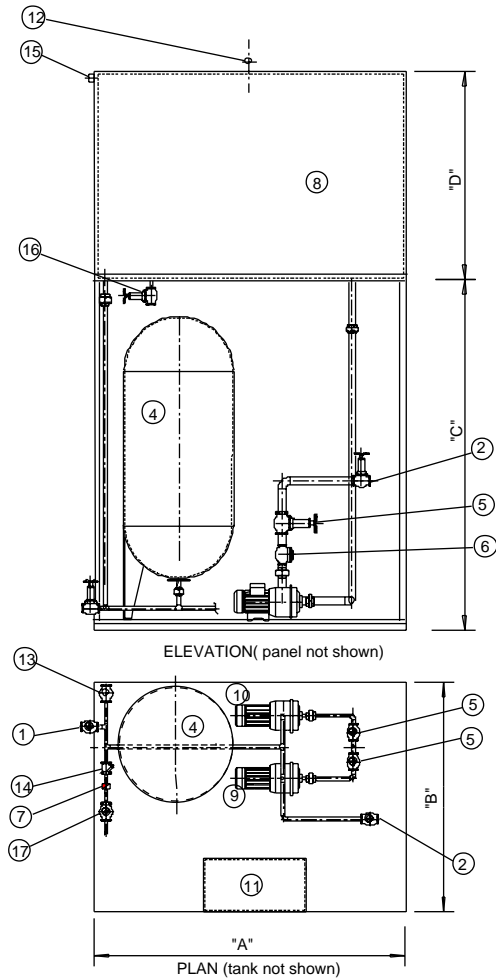

Fig 3: Custom built arrangement shown, with twin cooling vessels for Medium Temperature Hot Water system (MTHW) and bespoke 2 x 5000 litre spill tanks end to end (as opposed to side by side).

GENERAL ARRANGEMENT DRAWING FOR AQUASPILL TA100-E UNITS:

The general arrangement for anTA100-E (Tank Above) pressurisation unit is shown below, although all units are manufactured to suit site conditions/requirements so actual layout and dimensions will differ from that shown. Please contact AquaTech-Pressmain for details.



1	DRAIN/TEST POINT.
2	SYSTEM CONN. 1"
4	PRESSURE VESSEL.
5	ISOLATING VALVE.
6	NON-RETURN VALVE.
7	TRANSFER SOLENOID.
8	SPILL/FILL TANK.
9	No. 1 PUMP.
10	No. 2 PUMP.
11	CONTROL PANEL.
12	FLOAT VALVE.
13	SAFETY VALVE.
14	STRAINER.
15	OVERFLOW. 1 1/2"
16	TANK DRAIN. 1"
17	LOCK-SHEILD VALVE.



Fig 4: Typical arrangement for "TA100-E" shown.

Fig 5: Typical TA100-E example

Maximum spill tank size for a TA100-E unit is 46-35-35 for standard units, with Optional larger spill tank sizes available subject to plant room height and additional cost.

STANDARD SPILL TANK DIMENSIONS FOR AQUASPILL UNITS:

Larger systems (and therefore larger spill tanks) can easily be accommodated, please refer to AquaTech Pressmain for advice.

Spill Tank Code	Max. dimensions overall in mm			Float valve size (min 1.0Bar mains)
	Length	Width	Height	
24-36-48	600	950	1320	1/2"
38-30-31	1000	800	890	1/2"
36-36-48	900	950	1320	1/2"
39-39-60	1000	1050	1625	1/2"
42-42-72	1100	1150	1930	3/4"
46-35-35	1200	950	990	3/4"
48-48-72	1200	1250	1930	3/4"
60-60-60	1500	1550	1625	1"
60-60-72	1500	1550	1930	1"
72-60-72	1850	1550	1930	1"
72-72-72	1850	1900	1930	1"

Table 2: GV100-E & TA100-E Spill tank data.

ELECTRICAL CONNECTIONS:

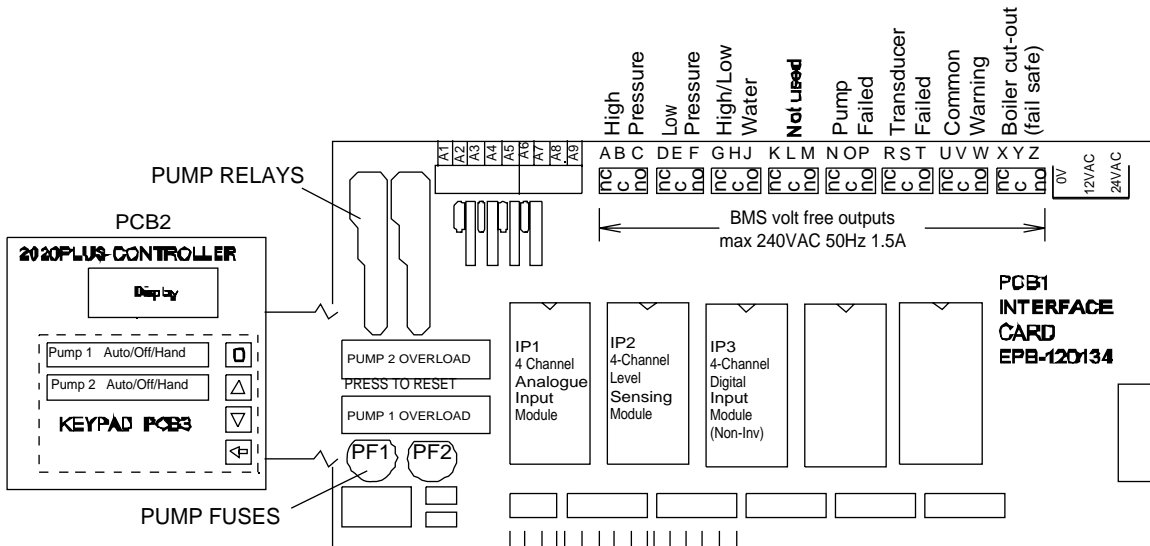

Typical Boiler Interrupt Circuit
(Wiring by controls contractor)

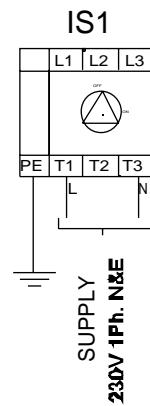
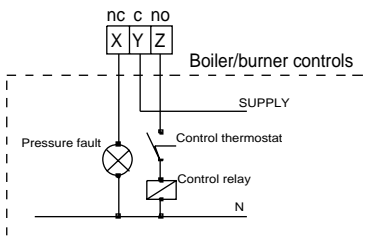

Fig 6: Typical electrical connections for GV100-E.

Electrical supply for AS2AV, GV100-E and TA100-E units: Single Phase, 230 Volt AC, 50Hz or 3 Phase, 400Volt AC 50Hz motors for larger applications. Please ask AquaTech-Pressmain for more details.

CONTROL PANEL FASCIA:

Typical control panel fascia layout is shown below, using the AquaTech-Pressmain 2020+ Micro-controller.

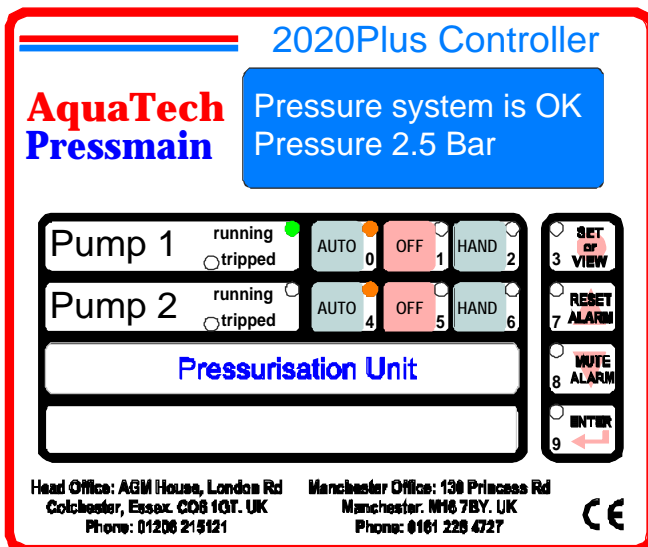

Fig 7:

TYPICAL SCHEMATIC PIPEWORK ARRANGEMENT:

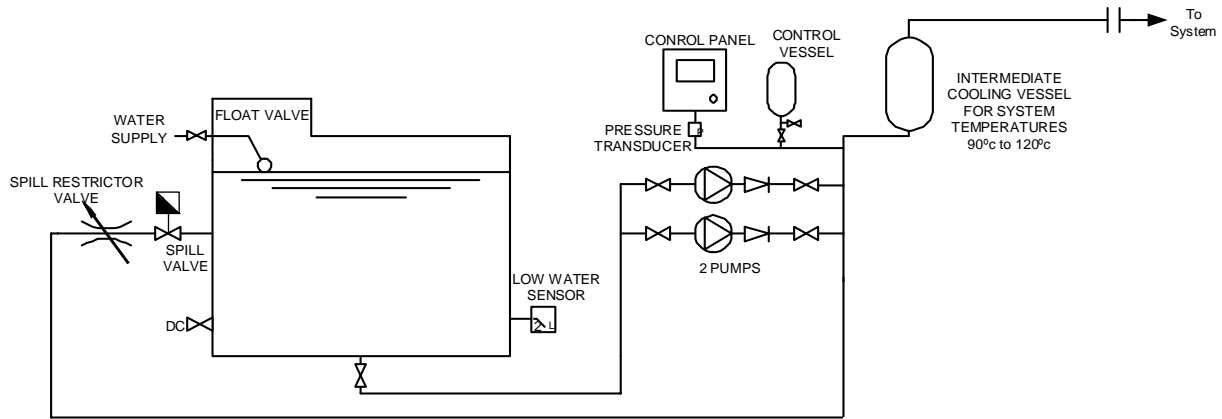

Fig 8:

WORK REQUIRED ON SITE:

1. Position pressurisation unit on raised plinth
2. Attach spill tank(s) where supplied loose
3. Connect correctly sized mains water supply to float valve, minimum pressure of 1 Bar required.
4. Connect overflow warning pipe to drain.
5. Connect to system pipework on underside of return pipe.
6. Connect mains electricity supply, boiler/chiller interlock wiring and BMS volt frees as required.
7. Contact AquaTech-Pressmain to have unit commissioned when ready.

CONSTRUCTION STANDARDS FOR AQUASPILL PRESSURISATION UNITS

ITEM	MODEL/SERIES	STANDARD/CLASS	REMARKS
Quality System	Manufacturing	ISO 9001:1994	Cert No. FM33090
Electrical Safety Standard		BS EN 60204-1:2006	EC Declaration of Conformity
Low Voltage Directive		73/23/EEC & 93/68/EEC	EC Declaration of Conformity
EMC Directive 89/336/EEC		EN61000-6-3 & EN61000-6-1	EC Declaration of Conformity
Pressure Equipment Directive		97/23/EC	EC Declaration of Conformity
Spill tank		Galvanised or Painted welded steel	Bespoke sizing
Mains water float valve	Drop arm	Equilibrium	Type AA or AB air gap
Pipework		Copper/Black iron	
Motors		TEFC IP44, Class F Insulation	Thermal overload protected
Control cabinet	2020+	IP55	425x425x200mm
Isolator Door Interlocked	GHA-030250	CE, UL, CSA, BS, IEC, VDE	
Microprocessor Controller	2020+	89/336/EEC compliant	
Pressure Transducer	392 – 10Bar	SS/Ceramic/Wras	
Control Vessel	VR 10Bar	BS6144	CE marked

Table 3:



Head office
AGM House, London Road, Copford, Colchester. CO6 1GT
T: 01206 215121 F: 01206 215131

Manchester Office
Dolphin House, 130 Princess Road, Manchester. M16 7BY
T: 0161 226 4727 F: 0161 226 5848

E: info@aquatechpressmain.co.uk
W: www.aquatechpressmain.co.uk



Leaders in the design, manufacture and assembly of fluid pumping equipment and control systems.
Applications: Cold Water Supply; Fire Fighting; Heating & Chilled System Pressurisation; Tank Monitoring.